

Алматы (727)345-47-04
Ангарск (3955)60-70-56
Архангельск (8182)63-90-72
Астрахань (8512)99-46-04
Барнаул (3852)73-04-60
Белгород (4722)40-23-64
Благовещенск (4162)22-76-07
Брянск (4832)59-03-52
Владивосток (423)249-28-31
Владикавказ (8672)28-90-48
Владимир (4922)49-43-18
Волгоград (844)278-03-48
Вологда (8172)26-41-59
Воронеж (473)204-51-73
Екатеринбург (343)384-55-89

Россия +7(495)268-04-70

Иваново (4932)77-34-06
Ижевск (3412)26-03-58
Иркутск (395)279-98-46
Казань (843)206-01-48
Калининград (4012)72-03-81
Калуга (4842)92-23-67
Кемерово (3842)65-04-62
Киров (8332)68-02-04
Коломна (4966)23-41-49
Кострома (4942)77-07-48
Краснодар (861)203-40-90
Красноярск (391)204-63-61
Курск (4712)77-13-04
Курган (3522)50-90-47
Липецк (4742)52-20-81

Казахстан +7(727)345-47-04

Магнитогорск (3519)55-03-13
Москва (495)268-04-70
Мурманск (8152)59-64-93
Набережные Челны (8552)20-53-41
Нижний Новгород (831)429-08-12
Новокузнецк (3843)20-46-81
Ноябрьск (3496)41-32-12
Новосибирск (383)227-86-73
Омск (3812)21-46-40
Орел (4862)44-53-42
Оренбург (3532)37-68-04
Пенза (8412)22-31-16
Петрозаводск (8142)55-98-37
Псков (8112)59-10-37
Пермь (342)205-81-47

Беларусь +(375)257-127-884

Ростов-на-Дону (863)308-18-15
Рязань (4912)46-61-64
Самара (846)206-03-16
Санкт-Петербург (812)309-46-40
Саранск (8342)22-96-24
Саратов (845)249-38-78
Севастополь (8692)22-31-93
Симферополь (3652)67-13-56
Смоленск (4812)29-41-54
Сочи (862)225-72-31
Ставрополь (8652)20-65-13
Сургут (3462)77-98-35
Сыктывкар (8212)25-95-17
Тамбов (4752)50-40-97
Тверь (4822)63-31-35

Узбекистан +998(71)205-18-59

Тольятти (8482)63-91-07
Томск (3822)98-41-53
Тула (4872)33-79-87
Тюмень (3452)66-21-18
Улан-Удэ (3012)59-97-51
Ульяновск (8422)24-23-59
Уфа (347)229-48-12
Хабаровск (4212)92-98-04
Чабоксары (8352)28-53-07
Челябинск (351)202-03-61
Череповец (8202)49-02-64
Чита (3022)38-34-83
Якутск (4112)23-90-97
Ярославль (4852)69-52-93

Киргизия +996(312)96-26-47

<https://mahle.nt-rt.ru> || men@nt-rt.ru



Innovations for
sustainable mobility

MAHLE

MAHLE is a leading international development partner and supplier to the automotive industry with customers in both passenger car and commercial vehicle sectors. Founded in 1920, the technology group is working on the climate-neutral mobility of tomorrow, with a focus on the strategic areas of electrification and thermal management as well as further technologies to reduce CO₂ emissions, such as fuel cells or highly efficient combustion engines that also run on hydrogen or synthetic fuels. Today, one in every two vehicles globally is equipped with MAHLE components.

MAHLE generated sales of more than EUR 12 billion in 2022. The company is represented with approx. 72,000 employees at 152 production locations and 12 major research and development centers in more than 30 countries.

(as of 31.12.2022)

#weshapefuturemobility

**Arnd Franz**

Chairman of the MAHLE Management Board and CEO

Dear readers,

The automotive industry is taking great strides toward sustainable mobility. We are seeing the new registrations of electrified vehicles increasing and the technology developing rapidly. In the case of passenger cars, the share of battery electric and hybrid drives could rise from 13 percent today to 70 percent in 2035. This trend will be primarily driven by markets such as Europe, North America, and China. In other regions, the internal combustion engine will continue to dominate for years with a production share of up to 60 percent. At MAHLE, we are doing our part to ensure that the development toward sustainable mobility continues. For fast-acting climate protection, we rely on technological diversity and develop sustainable solutions in the areas of electrification, thermal management, and highly efficient green combustion technologies.

System expertise is becoming increasingly important: in electric vehicles, for example, the interaction of the individual component is much more complex than in vehicles with combustion engines. As an innovative system provider, we are able to offer our customers solutions that are more powerful, more efficient, and at the same time less complex.

In e-mobility, we focus on electric drives and intelligent charging. We are committed to making e-mobility user friendly, reliable, and, above all, affordable. We constantly demonstrate our innovative strength: in 2022, around 70 percent of patent applications by MAHLE were in this field.

Efficient electrification does not work without efficient thermal management. MAHLE is one of the largest suppliers of thermal management systems for batteries, efficient drives, and sophisticated cabin comfort. We serve all drive types and vehicle classes. This branch of technology opens the door for further innovations in all drive areas.

In addition to electric drive forms, highly efficient and sustainable combustion engines will remain a relevant factor worldwide for years to come. MAHLE will drive efficiency progress in this segment with state-of-the-art products. This includes the use of hydrogen and e-fuels. Our customers appreciate that, as part of our strategy, we will continue to support the combustion engine as long as there is demand.

This diversity will allow us to shape the future of mobility. You can find out what this looks like in detail in this magazine.

Enjoy reading!

Arnd Franz

2.



1.



3.



4.



5.

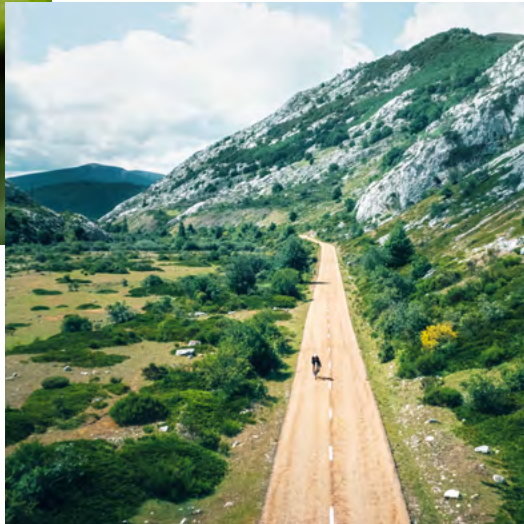

Content

Three paths to green mobility	6
MAHLE on site	8
MAHLE portfolio	10
1. E-mobility	
E-volution with a system solution	12
Perfectly coordinated	14
Quiet drives	16
Scalable charging solutions for everybody	18
The best for the electrons	20
2. Thermal management	
Comfort all year round	22
No E without T	28
Climate specialists	30
3. Conventional drives	
Moving faster toward sustainable mobility	34
Clean addition	36
High performance from the 3D printer	37
4. Sustainability	
Moving sustainably	38
Green milestones	40
5. Urban mobility	
Freedom ahead	42
All in the frame	44
Fully connected	45
MAHLE solutions for Smart Bikes	46
Scooters and commercial vehicles	48
The street in the laboratory—climatic wind tunnel	50
R&D experts—MAHLE Powertrain	52
Keeping everything running—MAHLE Aftermarket	54

Three paths to green mobility

MAHLE is focusing even more strongly on electrification, thermal management, and components for highly efficient, green combustion engines as this forms the core of the corporate strategy. All three tracks have one goal: climate-neutral mobility of tomorrow.

The future of mobility is battery-electric or hybrid. This is particularly true for Europe, North America, and China. But clean and efficient combustion engines and hydrogen drives are also part of the drive mix of the future. This is because developments will vary greatly depending on the region of the world. This applies equally to passenger cars and trucks. In emerging markets in particular, the market for vehicles with internal combustion engines is expected to continue to grow, for example in India or South America. Here, sustainable fuels, such as e-fuels or biofuels, will rapidly contribute to the decarbonization of road transport.

At the core of the new MAHLE 2030+ corporate strategy is the MAHLE Mission “Efficiency in Motion”, which combines all the Group’s activities in the three strategic areas and serves as the strategic lever for implementing the MAHLE Vision “We Shape Future Mobility.”

1. Electrification: the E-volution continues

Electrification is where the greatest market momentum lies. Between 2022 and 2026, more than 20 electrified vehicle platforms from leading passenger car and commercial vehicle manufacturers will be launched on the market that rely on MAHLE technology and products. Our strategy is primarily focused on the e-drive and intelligent charging. We electrify all vehicle classes—from e-bikes and scooters to passenger cars and commercial vehicles. MAHLE already sells more than 8 million e-drives per year for automotive, industrial, and urban mobility applications.

2. More climate expertise: thermal management

With our in-depth expertise in thermal management, an important element of electrification, we are a technology driver for e-mobility. Our strategy is aimed at further expanding our established status as a systems provider focusing on energy efficiency and air conditioning. MAHLE is one of the largest suppliers of thermal management systems for batteries, efficient drives, and sophisticated cabin comfort.

WE SHAPE
FUTURE MOBILITY

3. Open to technology in the future: modern combustion engines

Highly efficient and clean combustion engines will remain a relevant factor worldwide for years to come. MAHLE pursues a strategy of cost leadership in components for internal combustion engines and thus remains a reliable partner for its customers. With lean structures, we will be competitive worldwide and take advantage of market opportunities. MAHLE will drive efficiency progress in this segment with state-of-the-art products. The internal combustion engine can make an immediate contribution to climate protection with non-fossil fuels, such as e-fuels. We see potential for the use of fuel cells and hydrogen engines, especially in the commercial vehicle sector.

70%

will be the market share of newly produced passenger cars with battery electric drives as well as fuel cell and hybrid drive solutions in 2035.

40%

of all commercial vehicles worldwide will be produced as purely electric with battery, fuel cell, or hybrid drive by 2035.

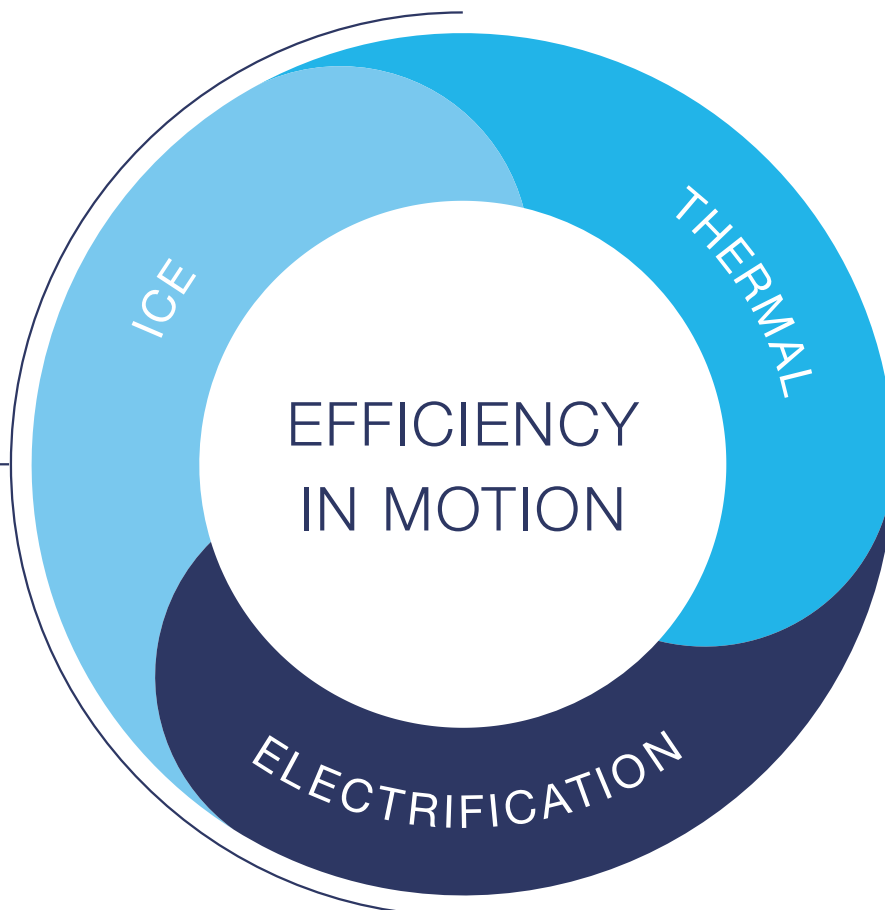

Europe

57 production locations

31,165 employees*

Austria, Bosnia and Herzegovina,
Czech Republic, France, Germany,
Great Britain, Hungary, Italy, Poland,
Portugal, Romania, Slovakia,
Slovenia, Spain, Türkiye

Asia/Pacific

58 production locations

16,432 employees*

China, India, Indonesia,
Japan, Philippines, Singapore,
South Korea, Thailand

Africa

2 production locations

818 employees*

South Africa

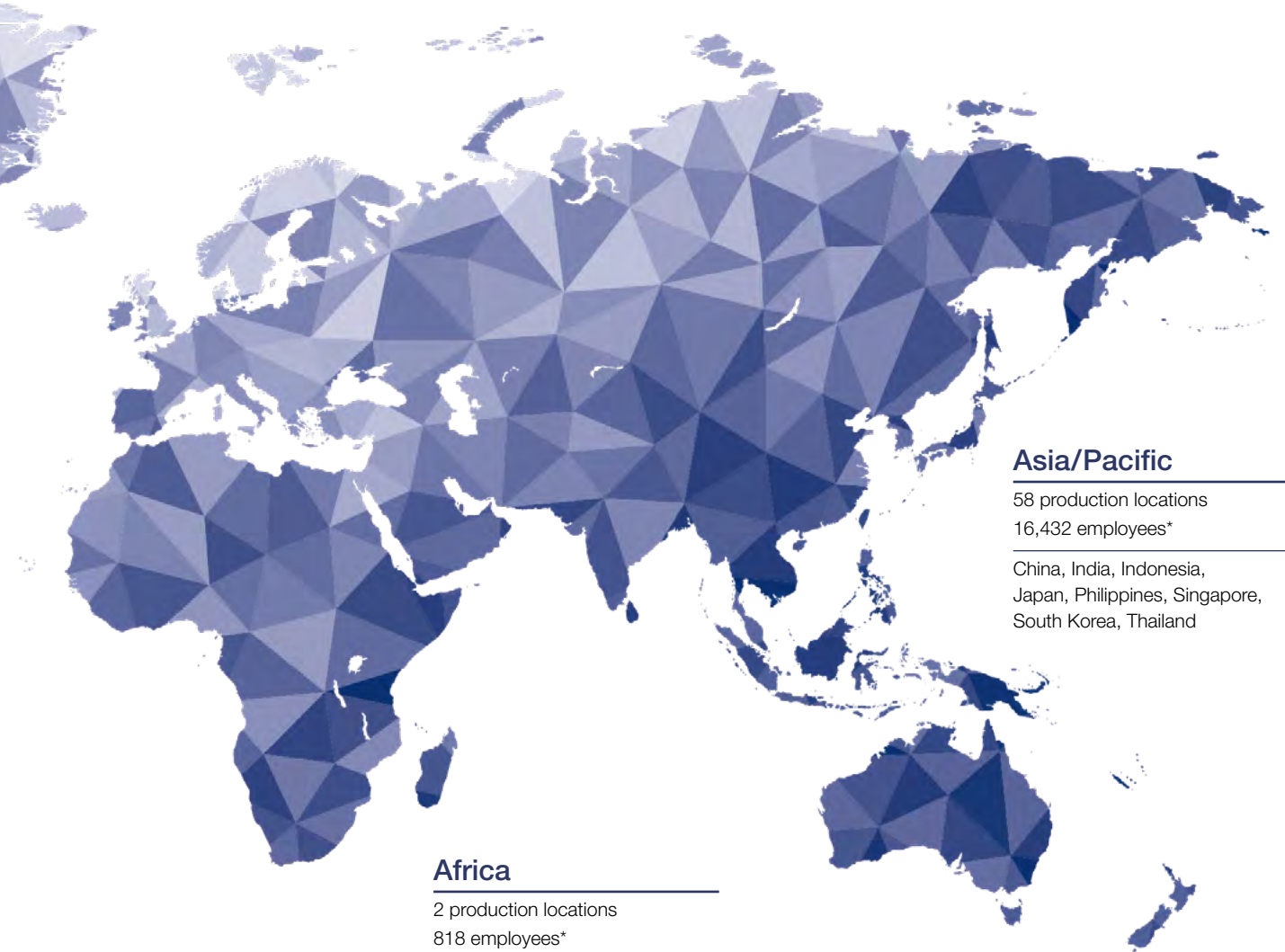

MAHLE portfolio



Electronics and Mechatronics

Electronic and mechatronic components play a decisive role in increasing the efficiency of the powertrain and the further development of electromobility. MAHLE already offers the right solutions here with its product ranges of electric drive systems, actuators, and auxiliary units as well as control and power electronics. They are used in many different applications and markets and are closely interlinked technically. This means economies of scale and synergies can be achieved, which is a crucial success factor in the automotive industry. MAHLE already sells more than 8 million e-drives and electric auxiliaries per year for automotive, urban mobility, and industrial applications.



Filtration and Engine Peripherals

To increase the efficiency and service life of engines and reduce emissions, MAHLE manufactures filters and oil coolers for motor and transmission applications for combustion engines as well as for alternative drives. MAHLE is developing solutions for active fuel cell drives in the area of alternative drives. The engine peripherals often differ even with an identical basic engine due to different regional emissions laws, individual body shapes, and different power classes.



Thermal Management

Innovative products from the field of thermal management for batteries, fuel cells, power electronics, and electric actuators enable long cruising ranges, high efficiency, and a long service life and thus play a decisive role in shaping the path toward zero-emissions drives. And in the case of combustion engines, more efficient cooling systems significantly drive the reduction of fuel consumption. Innovations in air conditioners enable novel design concepts in the cabin and contribute to a high level of climate comfort in the vehicle as well as to increased efficiency.

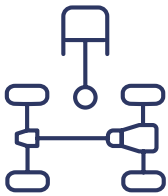

Engine Systems and Components

The development of piston systems and cylinder and valve train components has been one of the core MAHLE businesses for decades. We understand the interaction of all engine components and can therefore offer our customers optimal solutions. Our products are used worldwide in two-wheelers, passenger cars, commercial vehicles, and large engines. MAHLE will drive efficiency progress with state-of-the-art products. We are also developing engine components for the use of sustainable fuels such as hydrogen and e-fuels.



Service Solutions

We use the expertise of our business units to offer the market innovative workshop equipment and complete solutions for the professional maintenance and care of vehicles. The range includes solutions for all drive systems and vehicle classes. In addition to tools for classic vehicle diagnostics and for determining the condition of traction batteries, the portfolio also includes complete packages for testing of exhaust emissions and the digital calibration of driver assistance systems.

E-MOBILITY

E-evolution with a system solution

The number of electric vehicles on our roads is growing rapidly. Car manufacturers around the world are making further improvements to the technology this development requires. MAHLE is able to support them thanks to decades of experience with electric, electronic, and mechatronic components from a wide variety of fields.

Whether in passenger cars, commercial vehicles, e-bikes, or forklifts—electric drives of all sizes have become an indispensable part of the mobility landscape. That's why e-drives are already a core part of MAHLE's business. This applies not only to purely battery-powered vehicles but also to hybrid vehicles of all performance levels.





Perfectly coordinated

We continue to make great strides towards the widespread electrification of mobility. At the product level, this means offering customers advantages with system competence. A look inside the glass vehicle shows how the complex interaction of the individual components works.

Efficient drives and smart charging are two crucial areas for vehicle manufacturers and, of course, end customers. We are working on this at MAHLE to make e-mobility affordable, user-friendly, and reliable. This is primarily achieved with system solutions in which the individual components are always designed to work together. The module's integrated functions simplify processes and reduce costs for customers.

One area in which MAHLE sees great potential for more efficiency is thermal management. Ultimately, the performance, cruising range, and service life of an electric vehicle also depend on the sophisticated management of heat flows. Keeping the battery and motor always at the right temperature prevents wear and tear. MAHLE develops solutions for the vehicle cabin, the powertrain, and the peripheral systems. Thermal management is required for all drive forms. The importance of battery electric vehicles and vehicles with fuel cells is increasing significantly.

1 Fluid management module for electric vehicles

Purified and demand-adjusted tempered fluid increases both the cruising range and service life of the e-drive.

> More on p. 31

2 Cabin filter

Conventional cabin filters with and without activated carbon are part of the HVAC (heating, ventilation and air conditioning) and remove dirt particles, gas molecules, and viruses from the air for passengers.

> More on p. 32

3 Air conditioning (HVAC)

Two- or three-zone temperature regulation and air distribution with adjustable footwell temperature and best-in-class acoustics create a feel-good climate.

4 Cooling module

Highly efficient and compact—MAHLE cooling modules ensure perfect temperatures in the battery electric vehicle.

5 Electronics cooling plate

MAHLE cools power electronics for systems with high power closer to the component, thus also increasing the service life of the electrical components and interfaces.

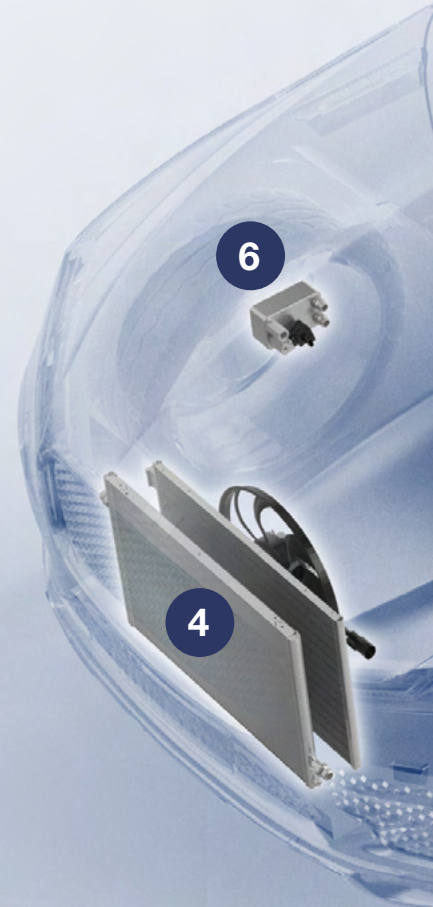

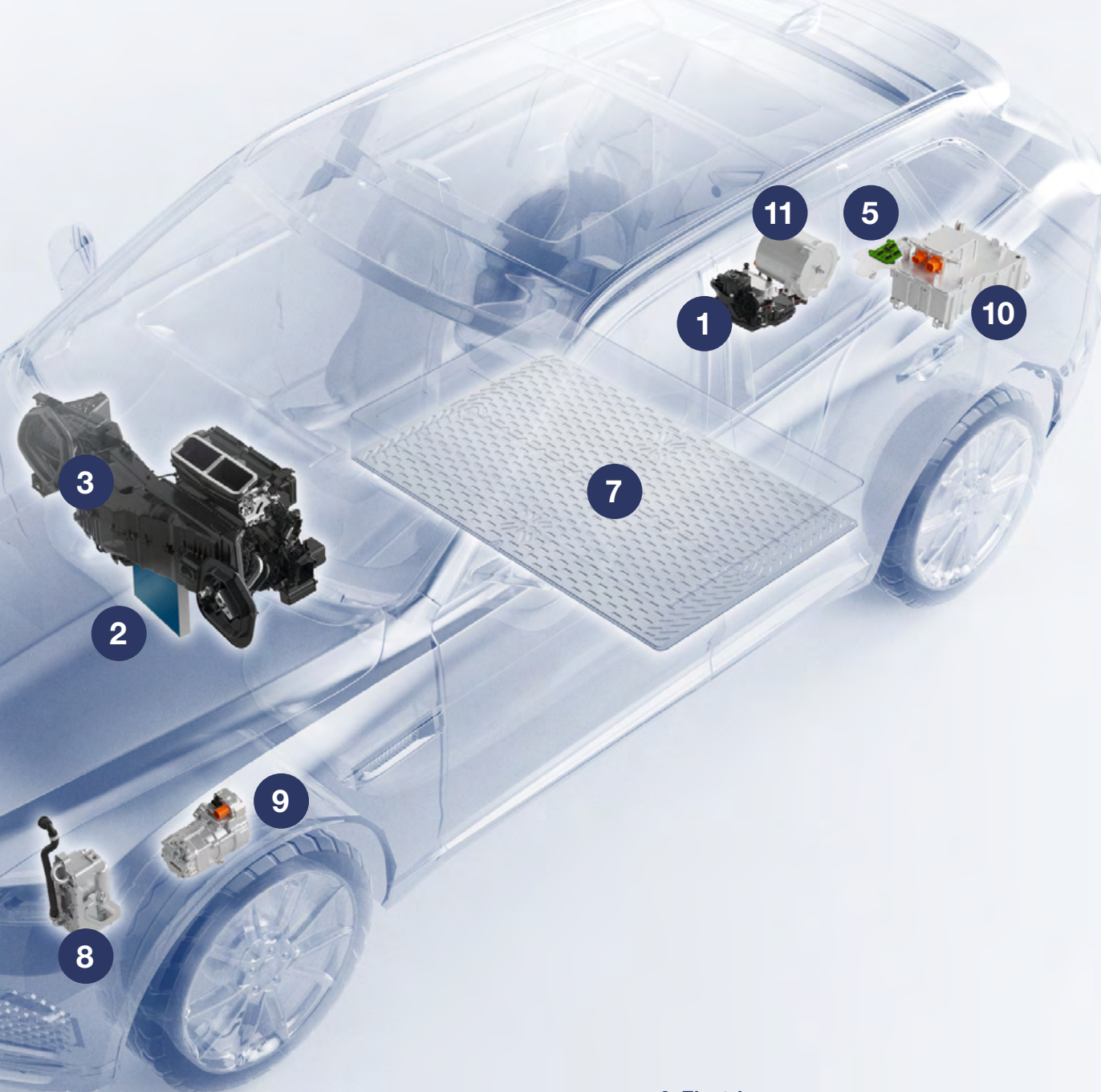

6 Chiller

The chiller with the MAHLE electric expansion valve transfers coolant between different cooling circuits.

7 Battery cooling plate

The temperature control keeps the battery temperature below 40 °C and increases the service life of the battery.

8 Indirect condenser

An indirect condenser is cooled with water during air conditioning and conversely heats coolant for heating purposes in heat pump mode.

9 Electric compressor

The heart of the air conditioning and refrigerant circuit: MAHLE offers air conditioning compressors for all relevant performance ranges and vehicle types.

> More on p. 31

10 The on-board charging system (OBC)

The on-board charging system ensures safe and efficient charging while continuously monitoring the temperatures.

> More on p. 20

11 MCT e-motor (Magnet-free Contactless Transmitter)

The innovative drive motor from MAHLE does without rare earths. The central feature of the new motor is the inductive and thus contactless power transmission. This allows the motor to function without wear and tear and ensures exceptional efficiency at high rpms. The efficiency is over 95 percent in the most frequently used driving conditions of the drive system.

> More on p. 16

Quiet drives

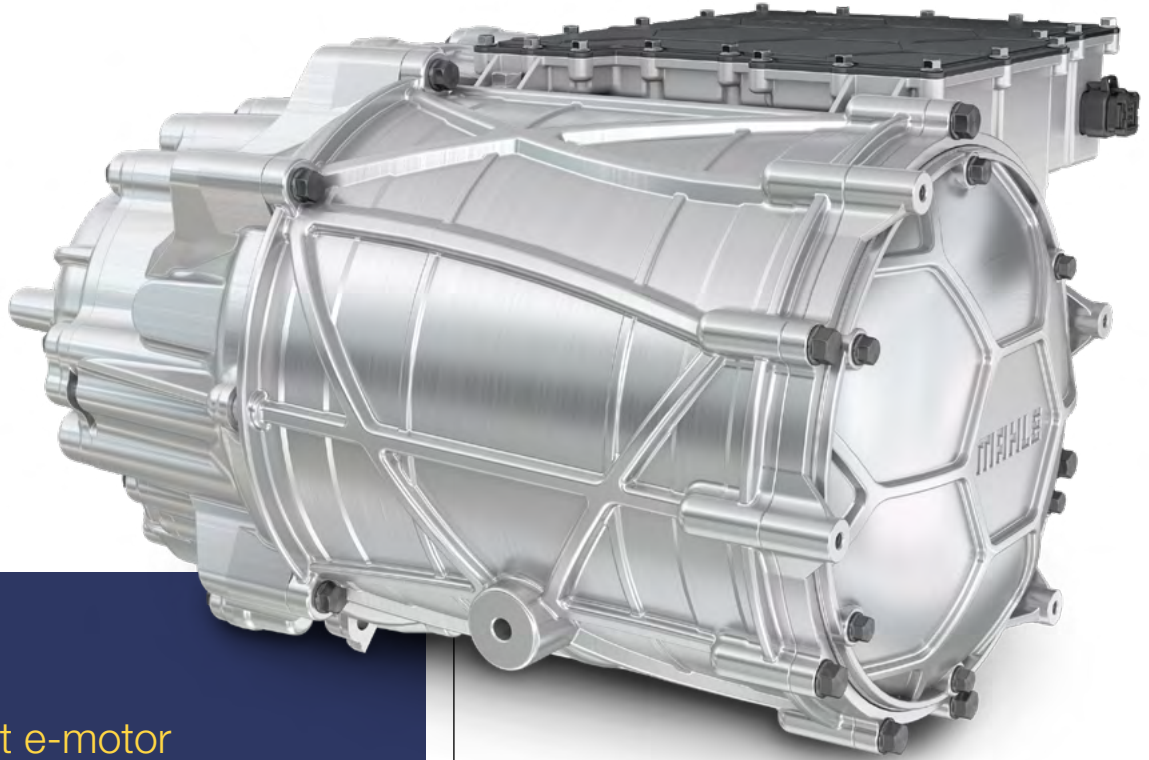

The perfect e-motor

MAHLE has succeeded in developing two benchmark technologies for electric motors over the past two years. For the first time, it is now possible to combine the MCT (Magnet-free Contactless Transmitter) and SCT (Superior Continuous Torque) technologies. The result is a unique modular system for electric motors that enables customized solutions for our customers. The perfect electric motor with the combined technologies combines permanent high peak power with contactless, wear-free power transmission. It dispenses with rare earths and demonstrates maximum efficiency at all operating points.

MCT E-motor – The magnet-free among motors

The magnet-free MCT-E motor (Magnet-free Contactless Transmitter) was a revolution in electric motor development when MAHLE presented it in 2021. This is because it does not require any rare earths. Another plus point is the wear-free power transmission. This means that it functions contactlessly on the inside. Where nothing touches, nothing can wear out! At the same time, the motor achieves 95 percent efficiency in all speed ranges. And last but not least, it is so flexible that it can be used in everything from small cars to commercial vehicles.



SCT E-Motor – Technological leap toward sustainability

With the SCT E-Motor (Superior Continuous Torque), MAHLE presented a true world-first in 2022. The traction motor—unique on the market—can run indefinitely with high performance, representing the first, true alternative to combustion engines. This technological leap is made possible by a new cooling concept. The new electric motor is unrivaled in its small size, light weight and efficiency, and can also be built without the use of rare earths at the customer's request. The new development is suitable for passenger cars, commercial vehicles, construction machinery and tractors. With the SCT E-motor, MAHLE becomes a full-range supplier in the field of electric drives and covers all needs from e-scooters to heavy commercial vehicles, offroad and industrial applications.



Rotor shafts for e-motors – Incredibly light. Incredibly strong.

E-vehicles sound so quiet and light that it is easy to forget that the same forces are at work as in conventional combustion engines. In e-vehicles, the e-motor transmits the generated

force to the rotor shaft. This comparatively slim component must therefore be designed to be extremely robust and light-weight at the same time. Because weight ultimately costs expensive range. The laser-welded rotor shaft from MAHLE is an impressive 30 percent lighter than comparable standard shafts. Nevertheless, it transmits torques of up to 1,000 newton meters or withstands 20,000 revolutions per minute. Thanks to the option of integrated oil cooling, it always remains within the optimum temperature window.



X20 e-bike drive system – The lightest drive for gravel, road or urban bikes

The innovative X20 from MAHLE is the lightest e-bike drive system on the market. It weighs only 3.2 kilograms, including the drive unit with a weight of only 1.4 kilograms, the integrated battery, and the HMI. It is thus the benchmark for the weight/power ratio of e-bike drives. The drive delivers 23 Newton meters directly to the wheel. In operation, this power is comparable to a mid-mounted motor, which has a torque of 55 Newton meters. The X20 system is complemented by the new e185 range extender. Weighing just 1.1 kilograms, it too is currently the lightest on the market. Fully charged, its 171 watt hours can fully support the integrated battery for up to 60 kilometers.



Scalable charging solutions for everybody

MAHLE chargeBIG offers scalable charging systems from one source. Three different solutions are available to municipalities, the housing industry, or fleet operators. All of them follow a new approach: The aim is not to charge as quickly as possible, but to provide as many charging points as possible in an intelligent and low-cost way.



Intelligent infrastructure for fleets and municipalities

Charging solutions for larger parking areas are an important factor for the spread of e-mobility. This applies to city centers, airports, trade fairs, or employee car parks. ChargeBIG18-36 offers a scalable, centralized infrastructure for all these cases. It can be integrated into the existing network infrastructure and into existing buildings at low cost and without lengthy conversions. The basic idea: “Charge as fast as necessary, not as fast as possible.” The chargeBIG system is therefore the optimal solution for locations where electric vehicles park for longer. It offers 18 to 100 or even more charging points, and operation and cost accounting work simply via smartphone using an app, meaning it is intuitive and in compliance with calibration regulations.

In addition to charging hardware, the complete package also includes installation, maintenance, service, and operation if desired. The maintenance effort is significantly reduced by the central arrangement of the electronics.

For smaller requirements, there is the MAHLE chargeBIG6 variant. The system is optimized for the charging management of residential complexes, workshops, and smaller businesses. It can charge up to six electric vehicles simultaneously at an existing house connection with up to 11 or 22 kilowatts. ChargeBIG6 is simple to install, inexpensive, and easy to expand. The charging system consists of a central control unit: the chargeBIG6 charging distributor. Billing is done via the already installed electricity meter.



For smart fast charging networks

We round out the offer with chargeBIG POWER. It is a smart and easily integrated charging infrastructure solution that manages loads intelligently. Together with a suitable buffer concept, it helps to quickly set up a smart fast-charging network that meets demand. The direct current charging system for hubs and highways boasts impressively simple operation and a superior charging performance.

The best for the electrons

Proper charging is a crucial issue for the user-friendliness of electric vehicles. MAHLE is therefore focusing on smart charging solutions. They bring the electrons most effectively to where they are needed: from the charging point to the load unit in the electric vehicle, from there to the electric storage unit, all the way to the most important component, the electric drive.



On-board charging system—safe and efficient

Whether at the socket with slow alternating current or at the charging station with faster direct current: The onboard charging system from MAHLE adapts to any charging situation and ensures safe and efficient charging. To do this, it keeps a constant eye on the temperature of the battery and the power electronics and monitors correct grounding as well as possible leakage currents. The electricity can be routed to other consumers inside and outside the vehicle, for example to the cell phone charging in the car or to the oven at home.

High power charging cooling unit — fast charging under all conditions

In order for fast charging stations to conduct the electricity to the vehicle batteries as quickly as possible, ideal temperatures are required, especially on hot days. MAHLE has developed thermal management modules specifically required for cooling fast charging stations. This makes fast charging efficient and quieter in any environment.

Cool all round—immersion cooling for lithium-ion batteries

The faster a battery charges, the more it heats up. Immersion cooling from MAHLE offers a new solution for this: a non-leaky fluid circulates around the individual battery cells, which lowers the temperature quickly and evenly. This particular form of cooling has three positive effects: Firstly, it extends the service life of the battery. Secondly, immersion cooling enables very fast charging. This improves the long-distance suitability and thus the attractiveness of electric vehicles. And thirdly, with immersion cooling, smaller batteries can be used. This will make e-cars cheaper, lighter, and more resource-efficient. In order to find the ideal battery configuration for every requirement, MAHLE offers innovative cooling with three cell types: prismatic cells, round cells and pouch cells.





Source: Siemens

Wireless charging—simple and convenient

The current features of smartphones will soon make it easier for electric vehicle owners to charge their batteries: inductive charging. Siemens is developing the infrastructure, and MAHLE is handling the automotive engineering and the user-friendly positioning system. A “transmitter” coil is placed at the bottom of the garage or parking space for this. If a vehicle parks on it, a magnetic field is generated and transmits the energy to the “receiver” coil in the car. The battery charges with a charging power of 11 kilowatts and a 92 percent efficiency—and without cables!



Receiver coil for mounting on the vehicle

THERMAL MANAGEMENT

Comfort all year round





The inside temperature in a vehicle always runs contrary to the outside temperature: in cold weather it should be comfortably warm inside, and in summer pleasantly cool. Especially in the transformation to e-mobility, this presents engineers with new challenges.

No cold fingers in winter



Anyone who drives to work in winter or rolls through snow-covered landscapes wants to be warm in the cabin, even in an electric vehicle. Offering this comfort without much loss of cruising range is technically demanding. “Even if an electric motor is working on both axles, the waste heat is not sufficient for a warm cabin,” says Dr. Harald Straky, Vice President Product Development Electronics and Mechanics at MAHLE. A heat pump helps with this. It draws energy from the ambient air and heats the cabin. Less energy from the high-voltage battery of the e-car is needed for heating. “An efficient heat pump means the reduction in cruising range in winter is up to 20 percent less,” says Dr. Busch. The heat pump does not provide the entire heating performance. The difference is taken over by a heater that reaches the desired temperature both quickly and efficiently. As soon as a charging stop is necessary, powerful high-voltage coolant pumps play an important role because battery cells also like to be pleasantly warm in winter. Before the charging stop, the battery’s cooling system is used to heat the battery cells up to temperature. Then the charged electrons find their place in the anode more quickly. The e-car reaches its maximum charging power faster. A charging stop with a preconditioned battery is shorter, gets you back on the road faster, and keeps you warm.

A cool head in urban traffic

Manila, Philippines. Here, the average daytime temperature is more than 31°C. Efficient cooling is therefore one of the most important features of a vehicle. And for pleasantly tempered air to flow through the cabin, it needs energy from the high-voltage battery. Fortunately, higher temperatures make for somewhat less energy consumption. But there are other challenges. "In a quiet e-car, you don't want to hear the hum of pumps, compressors and fans," says Dr. Roger Busch, Corporate Executive Vice President Sales at MAHLE. The air conditioning auxiliary elements have to do their work as quietly as possible. And regardless of the temperature, perfect air conditioning also includes fresh air in the cabin. The nano-fleece and activated carbon in the air filters of the MAHLE solution frees the incoming air from pollutants and unwanted particles. So you can breathe freely with a relaxed ride.

From the manufacturer's point of view, there are two further points: every compressor and pump require valuable installation space and must be supplied with energy. The developers' challenge is thus to make them small, quiet, and energy-efficient. Our answer to this is the compact thermal management module. It combines, for example, a heat exchanger, coolant pumps, condenser, chiller, sensors and valves in one unit. This saves installation space, development effort, and costs.







Efficient in the future

Detached from drive technology, regulating temperature circuits is always also about performance and efficiency. For example, all vehicles need electric oil pumps. They can be used in hybrid drive systems, electric motors, and fuel cell drives to ensure lower emissions. The more precisely the pumps regulate oil quantity and oil pressure, the lower the fuel consumption. "Oil pumps continue to perform an important task in classic traction motors," says Dr. Uli Christian Blessing, Vice President Product Development Thermal Management at MAHLE. With regard to the holistic view, he continued: "The complete thermal management system also protects against overheating." For this purpose, heat is transferred from the oil to the coolant circuit.

Thermal components can also help reduce emissions with clean combustion technology. One example is the use of carbon-neutral fuels such as ethanol. With over 100 years of experience, MAHLE has developed engine components that meet the special requirements in terms of wear and blow-by effect. That means gas that enters the crankcase during the combustion of ethanol or hydrogen is directly enriched with air by a high-pressure impactor. This means no ignitable gas mixtures are created. This turns the internal combustion engine into a safe and clean solution.

No E without T

Heating and cooling in electric vehicles is an essential technology field for electrification—and a MAHLE core business. New innovations increase the cruising range and fast-charging capability of batteries and bring more comfort to vehicle cabins. The chart shows that MAHLE always has the whole system in mind.

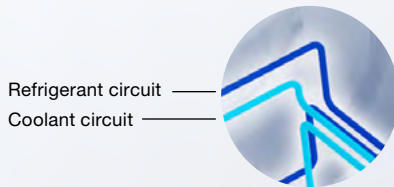

- 1 Thermal management module**
> More on p. 30
- 2 Electric compressor**
> More on p. 31
- 3 Cooling module**
- 4 Air conditioning (HVAC)**
- 5 MCT E-motor**
> More on p. 16
- 6 Fluid management module**
> More on p. 31
- 7 On-board charging system (OBC)**
> More on p. 20
- 8 Battery cooling plate**

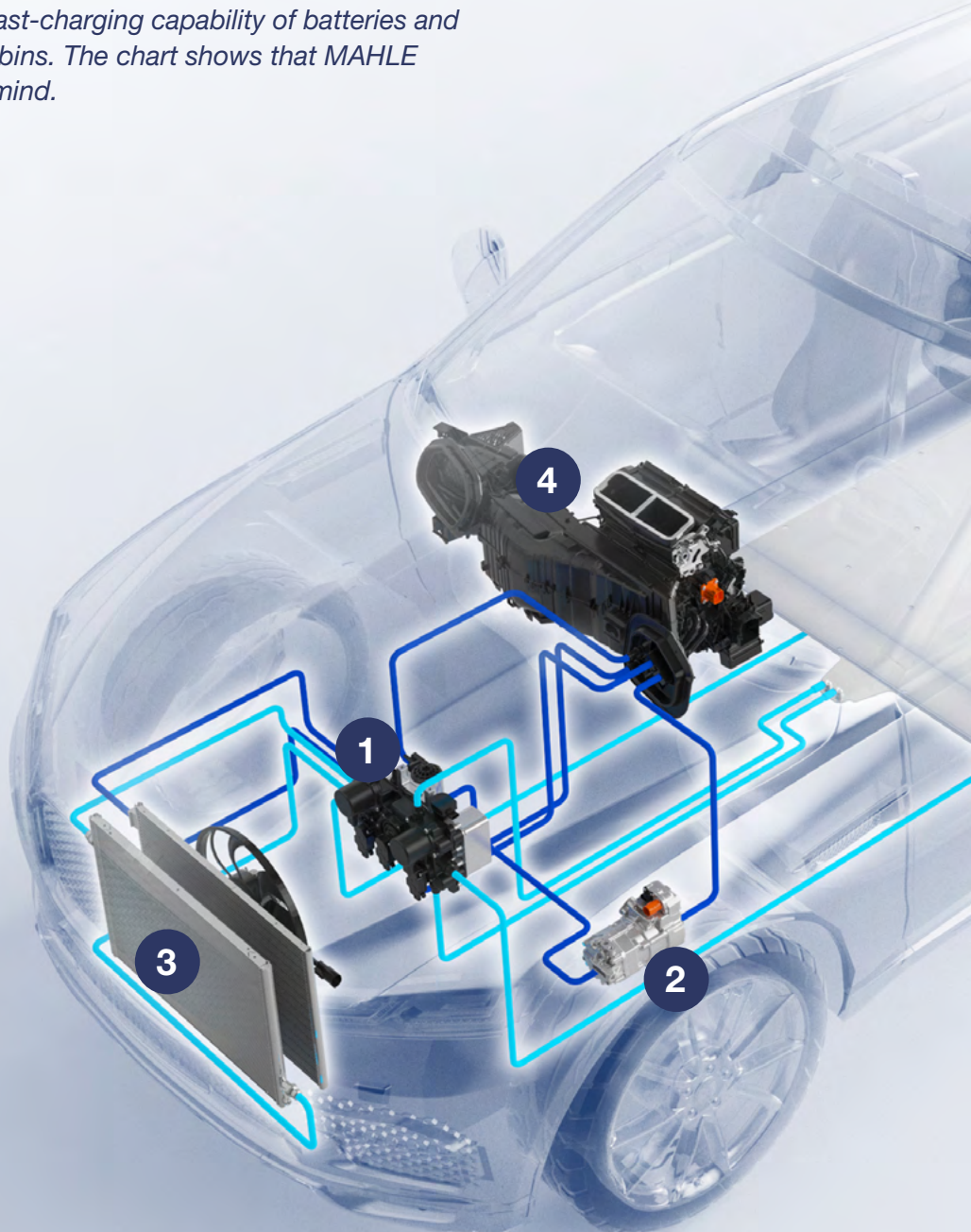

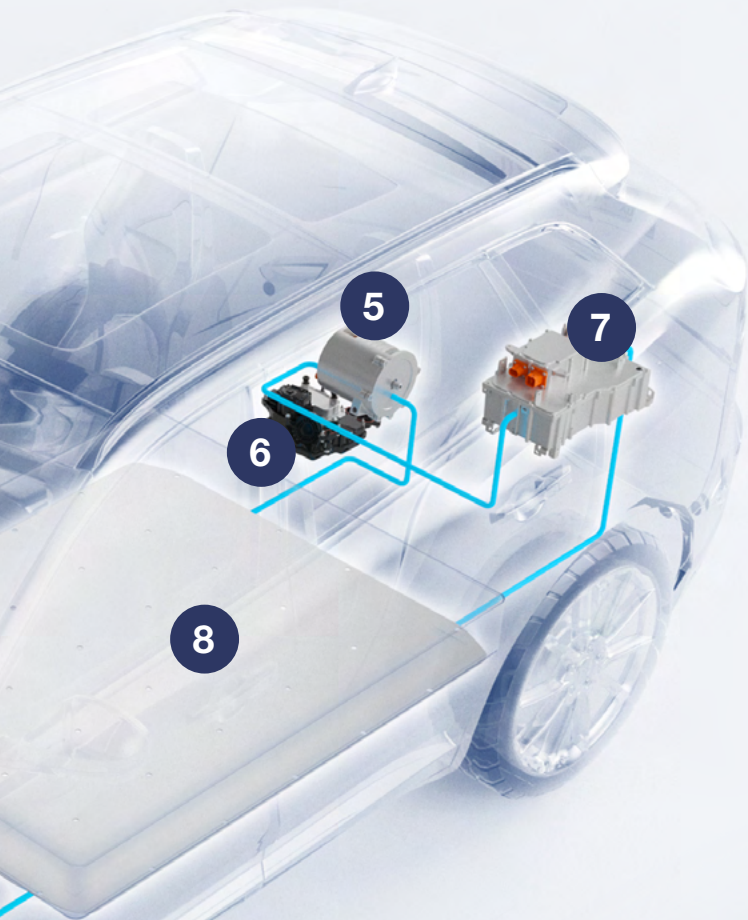

In the case of e-cars, end customer acceptance also depends on thermal management as the service life of the battery, the cruising range of the e-car, the performance of the drive system, and the fast-charging capability affect the driving experience. Components of the drive system require the correct temperature at all times. At the same time, thermal management ensures a feel-good climate in the vehicle cabin. Both processes require an understanding of the complete system.

MAHLE has developed a new thermal management module based on this. It combines, for example, a heat exchanger, coolant pumps, condenser, chiller, sensors and valves in one space-saving unit. Efficient and quiet electric fans and powerful air conditioning compressors complete the offer. Another successful product is battery cooling plates, which ensure fast charging, long range and long service life for sensitive lithium-ion batteries. Innovative heat pump systems reduce the energy consumption of an electric vehicle and make it possible to install smaller and lower-cost batteries. MAHLE is thus using its strengths to further advance sustainable mobility.

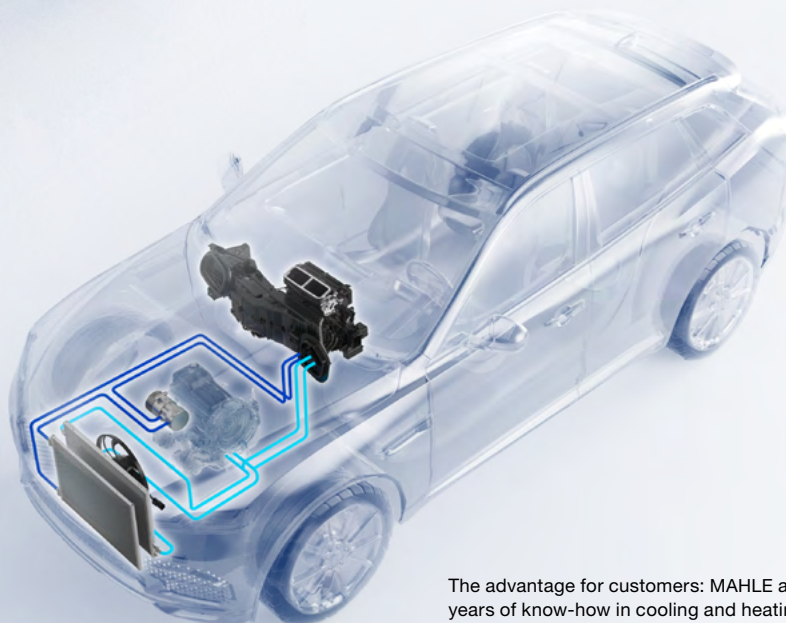

The advantage for customers: MAHLE also continues to use its many years of know-how in cooling and heating in the combustion engine.

Climate specialists

Compared to combustion technology, the demands on thermal management in electric vehicles are significantly higher. MAHLE therefore already has new solutions that make battery-electric vehicles and hybrids more efficient and also help in conventional vehicle types.



Thermal management module— All for one, one for all

The thermal management of modern electric vehicles consists of complex, closely coupled fluid circuits. Refrigerants and coolants perform different tasks in them. All critical components—interior, battery, electronics and electric motor—must be kept within the optimum temperature window. In the cold season, in turn, a highly efficient heat pump helps save heating energy. Compared to the standard system, this increases the range by up to 20 percent. MAHLE has reduced the many components required in this complex interaction to a single module: the thermal management module. Maximum performance and compact integration are the hallmarks of this approach.

Oil management module— Highly integrated, extremely compact

The cooling of traction motors is of major importance. They are the true “power packs” and must be protected from overheating. MAHLE’s oil management module is a highly integrated, extremely compact component especially designed for this important task. In a heat exchanger, the heat from the oil is transferred to the coolant circuit. The oil pump is integrated into the module.



800-volt e-compressor— The heart of thermal management

The e-compressor is important for the temperature control of the e-drive and thus crucial for the service life, high charging speed and range of the battery. It also ensures the high level of interior comfort and pleasant interior acoustics. MAHLE currently offers its extremely compact high-voltage compressor in voltages of up to 900 volts, displacements of up to 57 cubic centimeters and outputs of up to 18 kilowatts. Its compact design, combined with its high performance, means that it can be used in all vehicle classes—from passenger cars to heavy commercial vehicles.

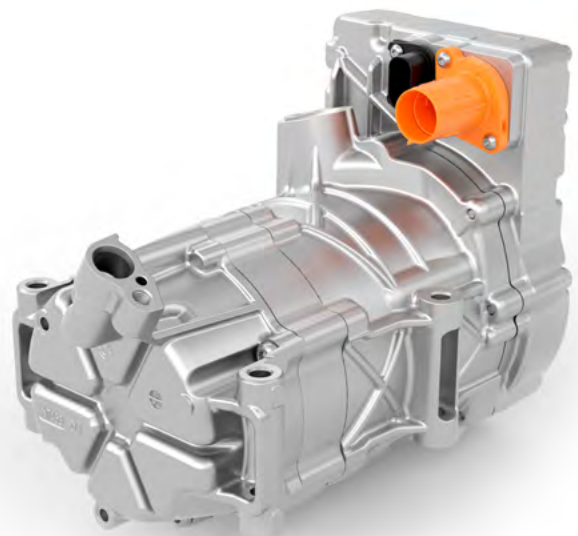

800-volt PTC heater— Comfortable temperatures, even in the cold season

Battery electric vehicles lack the heat from the combustion for interior heating in the cold season. Here, a highly efficient heat pump can often provide pleasant interior comfort. But every now and then, additional heating must be provided electrically. The 800-volt PTC heater from MAHLE heats the interior air directly. This is fast and highly efficient, with up to eight kilowatts of heating power.



Cabin air filter with nano-fleece and activated carbon layer—Clean cabin air for perfect cabin comfort

Perfect cabin comfort includes cabin air that is free of pollutants and undesirable particles. The new cabin air filter from MAHLE consists of two highly efficient filter layers: the nano fleece and the activated carbon layer. The nano-fleece effectively filters coarse dust, soot particles, and pollen from the air. It separates the smallest fine dust particles in the size of one micrometer up to 99 percent. But it also retains even smaller particles of 0.1 micrometers very well. The active carbon layer, on the other hand, effectively adsorbs harmful gases such as hydrocarbons, nitrogen oxides or sulfur dioxide. At the same time, the filter medium is only around 2 to 3 millimeters thin, which means that the pressure loss of the conditioned air through the filter is extremely low.

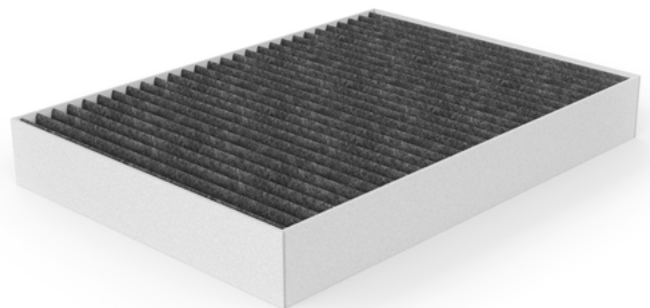

Fluid pump (12/24 V)— As fast as necessary

The fluid pump from MAHLE drives the coolant circuits. The pump is operated demand-driven with up to 650 watts at 12 volts. Demand-driven means: In order to save precious electrical energy, the pump always runs only as fast as conditions currently require. In the MAHLE concept, the pump bearings are also actively lubricated and the electronics are cooled. This protects against wear and ensures a long service life. MAHLE also offers the pump in a 24-volt version.



Electric oil pump family— Suitable for every application

Whether purely battery-electric drives, hybrid drive forms, or fuel cell drives: MAHLE offers the right electric oil pump for every application. The oil pump family from MAHLE is scalable in terms of power as well as the number of suction and pressure stages. Thus, power ratings of up to 250 watts are representable, with 24-volt drive power. MAHLE offers optional 24-volt and 48-volt systems. Controlled via LIN or CAN interface, the product family covers all typical requirements of e-drive axles. If necessary, the pump can be individually adapted to the respective customer requirements.



CONVENTIONAL DRIVES

Moving faster toward sustainable mobility

E-mobility is the key solution for climate protection in road traffic. However, to reduce CO₂ more quickly, all technically possible solutions are necessary. Also with a view to the existing fleet with combustion engines.

Which powertrain technologies will get people and goods to their destinations reliably, efficiently, and cleanly in the future? Not a simple question. E-mobility is the key solution for climate protection in road traffic, but the diversity of regional requirements calls for solutions that are open to technology. Globally, the combustion engine will remain the most common drive form for the next few years, especially for commercial vehicles. MAHLE is equally dedicated to conventional and alternative drives in order to exploit all opportunities to reduce emissions in road traffic quickly and effectively.

Alternative fuels from renewable sources offer great potential for precisely this purpose. The enormous advantage is that an immediate effect on climate protection is achieved in the vehicle fleet that exists worldwide. In many countries, for example, green ethanol is available as a fuel. But green hydrogen is also part of the energy transition, for example for heavy-duty and off-road applications that are currently difficult to convert to battery-electric and fuel cell drives.





Clean addition

Ethanol power cell unit— Classic drive. Re-thought.

MAHLE uses its expertise in combustion engines to make components for this classic form of drive fit for use as a CO₂-neutral solution in global applications. This means that they can continue to be used with sustainable and CO₂-neutral fuels such as ethanol in a highly efficient manner and with a long service life. The Power Cell Unit (PCU) is optimized to meet the specific requirements of ethanol, for example with regard to blow-by, i.e. the escape of combustion gases from the PCU. Ethanol also places special demands on wear resistance. MAHLE has developed particularly exposed components such as valves and valve seat inserts accordingly.



High pressure impactor for hydrogen power cell units—Active and safe

During combustion in the cylinders, a small portion of gas always ends up in the crankcase—the so-called blowby gas. The high-pressure impactor actively flushes the crankcase with air, thus preventing alternative fuels (e.g. hydrogen) from accumulating here so that they can ignite.

High performance from the 3D printer

MAHLE has had initial success in producing a high-performance aluminum piston using 3D printing. The test shows that the special component increases engine output and efficiency.

MAHLE is leading the way technologically in design and production with additive production of highly loaded drive components. It offers the possibility of implementing functional integration as well as bionic design in a MAHLE component. In the production of high-performance pistons, more material is used only in loaded areas, following nature's example. This makes the 3D-printed piston up to 20 percent lighter than its conventionally manufactured counterpart, while still ensuring greater rigidity. For this purpose, the MAHLE developers have introduced a specially shaped cooling channel and used a new aluminum alloy. This was melted by laser beam and built up in fine layers. A piston blank was ready in about 12 hours and about 1,200 layers.

Quality confirmed in tough test run

Tested and finished, it then went into a real endurance test: six pistons were installed in the motor of a Porsche 911 GT2 RS. On the test bench, the drive unit successfully completed 200 hours of the endurance test under the harshest conditions. The result of the elaborate tests was that the quality of the printed piston corresponds to the usual high quality of a conventionally manufactured production piston. It thus combines efficiency and peak performance in a new dimension.

New 3D printing center

MAHLE sees additive production as the future, especially for the faster development and even series production of components in the field of electric vehicles and alternative drives. A new 3D printing center was opened in Stuttgart for this purpose.



22 kW

of extra power is produced by the Porsche 911 GT2 RS engine thanks to the special piston.

Achieving climate-neutral production

MAHLE aims to have climate-neutral production at all its locations worldwide by 2040. To this end, we have drawn up an ambitious roadmap, one goal of which is to increase our own electricity production. A good example of how we can combine our decarbonization technologies with our CO₂ targets is the cooperation with Sunmaxx PVT from Dresden. The start-up is developing photovoltaic-thermal systems, which create power and heat from solar energy. MAHLE supplies a cooling plate for this purpose, which was developed with know-how from automotive engineering. It becomes the key component for energy efficiency and increases energy production by up to 80 percent in the Sunmaxx PVT photovoltaic system. A pilot installation in the MAHLE plant in Vaihingen an der Enz is already being planned.

Further increasing the proportion of women

A central element of our diversity and inclusion strategy is the promotion of women in managerial positions. In order to achieve a more balanced gender ratio in the company's man-

agement ranks, new five-year targets have been set for the proportion of women at both levels below the management board: The target is to increase the proportion of women globally to 10% at the first management level and 15% at the second level by 30 June 2027. A mix of different HR measures, such as a more targeted focus on female successors in succession, development and recruitment, women's advancement programs as well as a range of flexibility offers should contribute to the achievement of the objective.

20%

of the MAHLE Supervisory Board are women. With this value, MAHLE 2022 was able to achieve an important milestone in the area of diversity.

In 2027,

10 percent of the first and 15 percent of the second executive level should be women.



2022 was marked by many global, geopolitical, and economic challenges. The fact that we were nevertheless able to stick to our sustainability activities and achieve important goals is a testament to the effectiveness and resilience of our sustainability strategy.

Kathrin Apel

Global Head of Sustainability & HSE at MAHLE



Green milestones

In 2022, we reached important milestones in the fight against global warming: We were able to reduce our CO₂ emissions from the use of fossil fuels (Scope 1) and emissions from the use of purchased electricity (Scope 2) by 12 percent in comparison with the previous year. In addition, we expanded our objectives for Scope 3, i.e. emissions along the supply chain.

By 2030, we want to reduce greenhouse gases in this area by 28 percent compared to 2019 and by 2040 we plan to be carbon-neutral in our production. To underline our commitment to achieving the goals of the Paris Climate Agreement, we submitted our Scope 1–3 targets by 2030 to the Science Based Targets Initiative (SBTi) for external validation.



Scope 1 & 2

Emissions caused by the company itself and consumption of purchased electricity and heat



Scope 3

Greenhouse gas emissions along the supply chains and product use

URBAN MOBILITY

Freedom ahead

Lightweight, sporty, and connected—these are the characteristics that set eBike systems from MAHLE apart. New solutions for the Smart Mobility and a variety range of accessories complete our innovations for Smart Bikes. More than 90 top-rate brands across the world have featured the technology supplied by MAHLE SmartBike Systems in their electric bicycles. For Urban, Gravel and Road cycling.



All in the frame

The lightest eBikes featuring drives from MAHLE combine powerful assistance with a low weight and discreet integration, making it possible to configure SmartBikes under 10 kg, ideal for the steepest and longest rides, ensuring high performance motor assistance. Furthermore, the riders who can manage without the motor's help don't feel resistance in the pedals when the system is turned off.

Ultra-compact smart systems offering a wide range of new possibilities for riding and manufacturers when designing the frame since the system is concealed within the bike's frame and rear hub, ensuring that electric bikes retain the appearance of conventional bikes.



10 kg

is how much the lightest eBikes fitted with MAHLE drive systems weigh.



The latest MAHLE systems innovations and technologies create the best support at any cadence, whether racing at top speeds or climbing up a mountain to drive the rider and the whole industry forward.



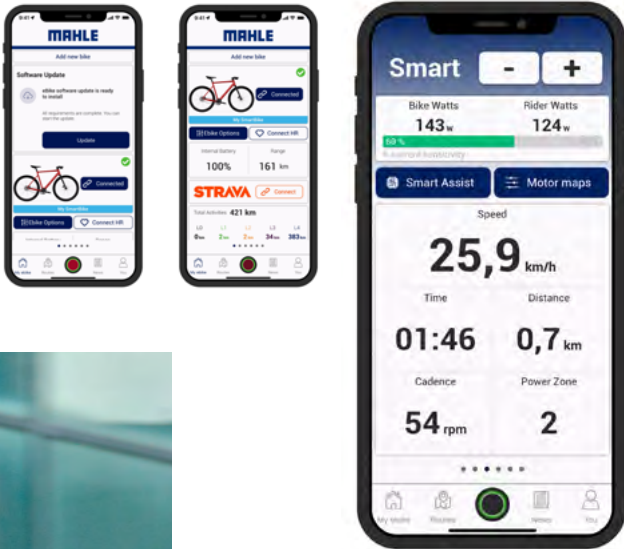

Fully connected

One of MAHLE's key focus areas is the complete connectivity of its drive systems. Two Apps are already available that can connect the Smart System to digital devices. An online dashboard also allows users to check key ride data or their Smart eBikes general status at any time. It's also a useful feature for brick-and-mortar specialist retailers, as they can offer servicing to meet the rider's particular requirements.

With this new form of connectivity, MAHLE is creating an unprecedented development of the entire SmartBike solution strengthening the relationship between the product, customers, manufacturers, and specialist retailers.

New features are among the future possibilities. For example, via intelligent sensors on the eBike or ANT+LEV communication protocol, MAHLE aims to raise the safety of riding and the ability to be permanently connected.

The development of the entire SmartBike solution also involves new technologies such as the Smart Assist which adapts the system's level assistance depending on what the rider needs at any moment to enhance the riding experience in more active way.

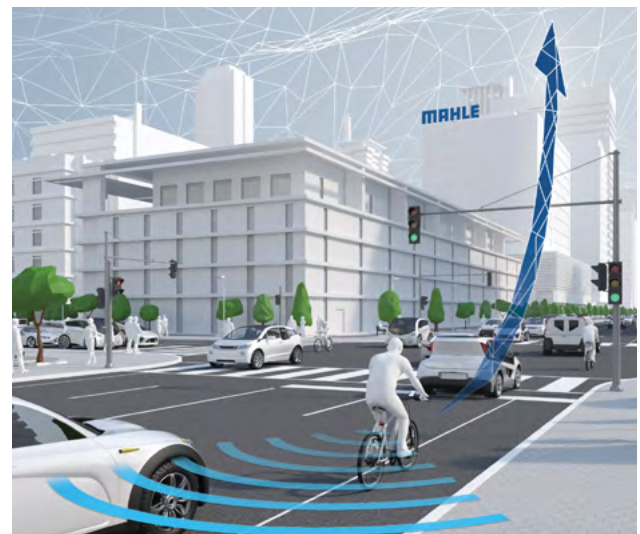

MAHLE solutions for Smart Bikes

The X20 System is the lightest and most awarded drive system on the market. Weighing in at only 3.2 Kg, it is also the most advanced in its class, with a seamless start and cutoff to the assistance and creating the best support at any cadence. Ultracompact, light and smart system that creates a full range of new riding possibilities offering a natural cycling sensation while making eBikes look & feel indistinguishable from high performance bikes.

1 X20 hub motor

The lightest drive unit on the market. Lightweight at only 1.399 kilograms, the rear hub motor is designed to reach a maximum performance level, applying power directly to the wheel and is completely unnoticed until feeling the 55Nm of torque. It includes the AMC system (Automatic Motor Connection, pending patent) that gets rid of motor cables and allows the wheel to be positioned naturally, fixing it through a standard 12 mm thru-axle.

2 HMI

Communication between rider and the Smart Bike takes place via the Head Unit Information System through a brightness sensor and 3D accelerometer, without interfering with the design and the riding experience. The Head unit allows, at a glance, to check battery level, assistance power, warnings, and alerts so the rider can focus on what is really important, the ride.

3 Smart batteries

The new smart batteries, 236Wh and 350Wh power the motor and can be supplemented with the external 171Wh Range Extender, providing, and assisting ride autonomy that can go beyond 140km, optimizing consumption thanks to the new generation of integrated motor controls. Integrated in the downtube, they can be quickly charged.

4 Torque and cadence sensor

The X20 System includes a sophisticated sensor package that measures each watt of power you apply, offering the rider the right support at any cadence, adapted to unexpected changes.





5 Range extender

MAHLE e185 is the only range extender that fits into a standard water bottle. Weighing only 1.1 kilograms, it has 171Wh of power to achieve the best weight-to-capacity ratio in this class. Fully charged, can support the integrated battery in the frame, extending the electric range for up to 60 kilometers.

6 Wireless PulsarONE display

For detail-oriented riders, the wireless PulsarONE display provides detailed information of eBike's key data. It's easy to operate and can also be used to change the level of assistance.

7 eShifters

At MAHLE, safety is a top priority. That's why we developed the eShifter, the perfect curved handlebar solution. They provide the rider with improved and seamless control of their bike, including two small control buttons, vibration technology and flexible placement of the included silicon bands.

Scooters and commercial vehicles



Two-wheel drive systems for scooters

E-scooters are agile, lightweight, and flexible. But there's also very limited space for the drive system. That's why MAHLE offers highly compact powertrain solutions for these motorized two-wheelers. Less powerful models generally use air-cooled IPM motors (interior permanent magnet synchro-

nous motors) and extremely space-efficient electronics. Each scooter is also fitted with a hybrid controller. It combines rotational speed and torque control for a dynamic handling experience. Larger and more powerful drive systems are usually liquid-cooled.



Low-voltage drives from MAHLE for scooters and three-wheelers with outputs of 5–14 kW



Induction motors for commercial vehicles and golf carts

MAHLE induction motors with the corresponding drive controllers are the ideal solution for electric micro commercial vehicles and golf carts. An algorithm regulates traction and adapts the torque smoothly and precisely to all ground and load conditions.

If required, the controllers can also contain drivers for braking resistors, which are used to brake the vehicle when the battery is fully charged.



Low-voltage drives from MAHLE for commercial vehicles and golf carts with outputs of 10–20 kW

The street in the laboratory

How can I increase the range of electric vehicles through optimal thermal management? How must systems for the heat pump be set up? Or: How do heat or cold affect the fast charging of Li-ion batteries? These and many other questions are asked by developers of almost all vehicle categories. They answer these questions in the MAHLE climatic wind tunnel in Stuttgart.



The first of its kind

As early as 1937, Manfred Behr built the world's first wind tunnel for the automotive industry. A year later, he used it to help the legendary W 154 Silver Arrow achieve a radiator design that set standards. As a pioneer in this field, MAHLE has continuously developed the measurement section to this day. The climatic wind tunnels enable realistic, precise, and repeatable measurement and test conditions for diverse applications. Therefore, they are the secure basis for smooth technology transfers, quality assurance, cost reduction, and time saving in the interest of the customers.

In the highly modern system, all conceivable conditions in driving practice can be precisely configured and reproduced. This means a wide variety of combinations and sequences of temperature, humidity, solar load, and street load are possible. Measurements can be carried out under real weather conditions for vehicle sizes up to trucks on the generously dimensioned measurement section.



For a clean future

Alternative drives based on hydrogen and battery-electric drives will determine road traffic in the future. The MAHLE climatic wind tunnel is gearing up for the future: Relevant tests, measurements, and simulations can be carried out there without any problems.

100 km cruising range in five minutes

Over 40 degrees Celsius heat, the sun burning on the car, almost no reprieve from the wind. These are difficult conditions for the temperature-sensitive Li-ion battery. If an e-car is then charged quickly, the battery can become too hot and be damaged. To be able to test this realistically, MAHLE has now equipped its climatic wind tunnel in Stuttgart with a direct current fast charging system. This allows up to 350 kW DC and 1,000 V to be charged in all climatic conditions. The 10-meter long cable reaches all charging ports without any issues. This allows the vehicle to be charged or discharged for a 100 km cruising range in under five minutes. The fast-charging station offers individual solutions for the wind tunnel, including monitoring and control from the control room.

New test procedures with hydrogen

Dealing with hydrogen in vehicle powertrains poses new challenges for manufacturers and for the climatic wind tunnel. Due to the chemical properties of hydrogen, the security concepts must be realigned, since an explosive mixture already exists at a hydrogen concentration of more than 4% by volume. The MAHLE experts carry out the corresponding tests on air-gas concentration in the climatic wind tunnel. Air movements during critical driving conditions become visible and can be analyzed. The ultimate goal is to conduct the tests with future drive concepts safely and under all climatic conditions.

R&D experts — MAHLE Powertrain

The next generation of drive technology will be more varied than ever before. As an experienced specialist in powertrains of all kinds, MAHLE Powertrain supports automobile manufacturers as they take their next step forward. Engine, transmission, hybrid unit, software, and operating strategy—MAHLE Powertrain handles it all.

If you're looking for expert engineering and consultancy services, MAHLE Powertrain is the partner for you—whatever the drive system. Its broad range of services includes the design, testing, development, calibration, and integration of hybridized internal combustion engines and electrified powertrain systems. In all projects, the ultimate goal is to achieve real innovations or advance to the next level of technology for solutions suitable for series production. As they move into the future, the experts are always there to support vehicle manufacturers as partners for cutting-edge research, development, and application.

Advanced testing

To stay one step ahead of the latest technology trends, MAHLE Powertrain continuously invests in state-of-the-art development and test infrastructure. This is also the case at the e-drive test center in Fellbach near Stuttgart/Germany, where the team is developing and testing e-axes and e-drive units for a wide range of electric and hybrid vehicles. To ensure compatibility with all potential vehicle drive applications, systems are operated with high-voltage and low-voltage batteries. Highly specialized permanent-magnet synchronous electric motors replicate the loads applied by the driven

wheels, while a thermal soaking system makes it possible to test e-drives in a wide temperature range.

Battery engineering partner

State-of-the-art simulation and testing are just two of MAHLE Powertrain's strengths. Thanks to in-depth understanding of new technologies, our experts also support the international automotive industry as a development partner. In the two battery development centers—one in Stuttgart and one in Northampton, England—we work on innovations for everything to do with batteries. At the same time, engineering services in this area are increasingly in demand. The newly developed 48-volt battery pack from MAHLE is a successful example of this within the MAHLE Group. It was designed with the support of





MAHLE Powertrain for repeated high-level charging and discharging to maximize the potential for energy recovery during deceleration and braking. The basis was data from the analysis of the driving behavior of a typical mid-range vehicle.

International presence

As the MAHLE Group's Engineering Services subsidiary, MAHLE Powertrain supports customers independently of the parent company in the selection of the most appropriate technologies or components for specific requirements. MAHLE Powertrain is represented internationally with eight locations in the UK, Germany, the USA, and China. This means that customers in the world's major automotive markets can work directly with our experts on site.



3

million euros were invested by MAHLE in the test bench for electric motors in Fellbach.

6

international centers offer customers on-site expertise in the UK, Germany, the USA, and China.



Keeping everything running

MAHLE offers its expertise throughout the life cycle of its vehicle technologies. That means high-quality spare parts and many services—from motorsports to workshop equipment. This is why we have the Aftermarket, Profit Center, and Services areas.

Sustainable outfitters: Aftermarket

With the growing series production of alternative drives, the spare parts and service business is also developing: A strong range here ensures long-lasting and more sustainable technologies. Thermal management in particular is gaining in importance as the number of electric and hybrid vehicles increases significantly. Across all technologies, workshops can rely on MAHLE equipment for vehicle diagnostics, battery testing, and service work to maintain air conditioning systems and automatic transmissions. MAHLE also supplies partners in the trade and engine repair, as well as electronic trading platforms worldwide with original equipment quality products. The aftermarket range is completed by services such as technical support at more than 30 locations worldwide as well as individual training courses and service information for all customers.

New challenges

The growth of e-mobility poses an unprecedented challenge to the automotive aftermarket and workshops in terms of the cost and complexity of battery systems. The battery itself can represent over 25 percent of the total vehicle cost. The share of vehicles with electric drive systems will rise to 95 percent in Europe, 90 percent in China, and 75 percent in North America by 2035. Battery service could therefore soon account for half of the total services provided by workshops. This makes it all the more important to develop suitable diagnostic and maintenance solutions.

New development partner

MAHLE is leading the way in this area, among other things via its cooperation with the US company Midtronics, Inc. The aim of the partnership is to provide workshops with a safe, simple, and effective service for the all-important Li-ion battery. The offer is intended to cover the entire life cycle of batteries and vehicles, irrespective of brand.

Workshop of the future

It is the workshops that ensure the mobility of millions of people worldwide every day. Our solutions take the load off the workshop operators' backs. Especially at a time when mobility is changing rapidly and different drive concepts are being developed, reliable and innovative partners are needed.

Calibrating with AI

MAHLE has released an update on the increasing calibration effort in workshops for driver assistance systems. The TechPro® Digital ADAS 2.0 system uses artificial intelligence. This recognizes the vehicle together with the control unit and automatically adapts the digital calibration panel from MAHLE to the respective vehicle. This saves several process steps per vehicle. To simplify the learning process, the application features 3D tutorials.

Maximum diagnostic possibilities

The MAHLE RemotePRO can help as a supplementary diagnostic system where universal diagnostic tools reach their limits. This is because it combines a large number of manufacturer diagnostic tools virtually on one server. This allows independent workshops to use the same range of functions as branded workshops, even on vehicles that are very rare or difficult to diagnose. This includes reading and erasing the fault memory, calibration, programming, and maintenance of various systems.



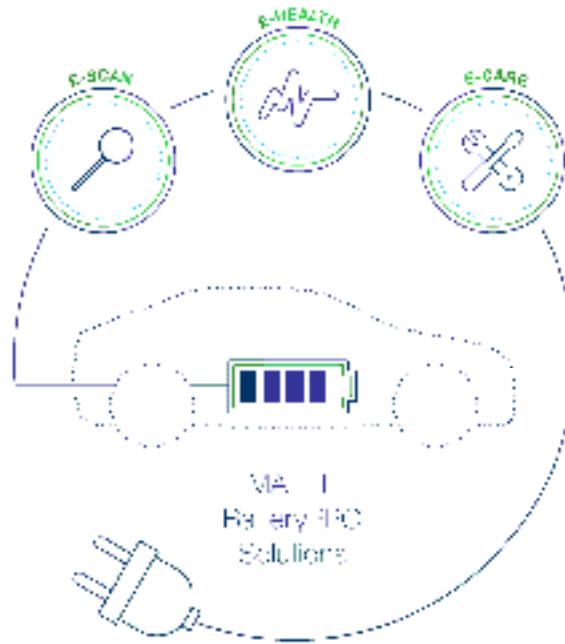

All-round healthy batteries

Since March 2023, MAHLE has been the first provider worldwide to enable independent workshops to carry out battery diagnostics on electric vehicles. For this purpose, our Aftermarket specialists have equipped their TechPRO® diagnostic tool with new software. But there is more to the complete package for healthy batteries.

E-Scan

The status of the battery can be monitored and printed in the corresponding report. The new function will be installed on the BRAIN BEE CONNEX and MAHLE TechPRO® diagnostic tools. The E-Scan is connected to the vehicle and detects all existing fault codes in an average of 30 seconds.

E-Health

E-Health means that in the future traction battery diagnostics will also work via the charging plug in addition to the existing OBD port. The process lasts about 15 minutes. The software evaluates the measured data in the cloud, regardless of what data the vehicle manufacturer provides via the OBD port. This makes the measurement particularly neutral and independent. In addition, the tool generates a forecast of the remaining expected life of the battery. The product launch is scheduled for the year 2023.

MAHLE diagnostic technology also makes it possible to combine charging and diagnosis. The E-Health Charge feature provides reliable information about the “health” of the high-voltage battery while it is charging. The measurement takes just a few minutes too.

E-Care

Vehicle and coolant manufacturers set certain replacement intervals for the coolants used. MAHLE offers a new service unit for the maintenance of cooling circuits. This enables workshops to offer additional services related to the supply of electric vehicles.

Алматы (727)345-47-04
Ангарск (3955)60-70-56
Архангельск (8182)63-90-72
Астрахань (8512)99-46-04
Барнаул (3852)73-04-60
Белгород (4722)40-23-64
Благовещенск (4162)22-76-07
Брянск (4832)59-03-52
Владивосток (423)249-28-31
Владикавказ (8672)28-90-48
Владимир (4922)49-43-18
Волгоград (844)278-03-48
Вологда (8172)26-41-59
Воронеж (473)204-51-73
Екатеринбург (343)384-55-89

Россия +7(495)268-04-70

Иваново (4932)77-34-06
Ижевск (3412)26-03-58
Иркутск (395)279-98-46
Казань (843)206-01-48
Калининград (4012)72-03-81
Калуга (4842)92-23-67
Кемерово (3842)65-04-62
Киров (8332)68-02-04
Коломна (4966)23-41-49
Кострома (4942)77-07-48
Краснодар (861)203-40-90
Красноярск (391)204-63-61
Курск (4712)77-13-04
Курган (3522)50-90-47
Липецк (4742)52-20-81

Казахстан +7(727)345-47-04

Магнитогорск (3519)55-03-13
Москва (495)268-04-70
Мурманск (8152)59-64-93
Набережные Челны (8552)20-53-41
Нижний Новгород (831)429-08-12
Новокузнецк (3843)20-46-81
Новосибирск (3496)41-32-12
Новосибирск (383)227-86-73
Омск (3812)21-46-40
Орел (4862)44-53-42
Оренбург (3532)37-68-04
Пенза (8412)22-31-16
Петрозаводск (8142)55-98-37
Псков (8112)59-10-37
Пермь (342)205-81-47

Беларусь +(375)257-127-884

Ростов-на-Дону (863)308-18-15
Рязань (4912)46-61-64
Самара (846)206-03-16
Санкт-Петербург (812)309-46-40
Саранск (8342)22-96-24
Саратов (845)249-38-78
Севастополь (8692)22-31-93
Симферополь (3652)67-13-56
Смоленск (4812)29-41-54
Сочи (862)225-72-31
Ставрополь (8652)20-65-13
Сургут (3462)77-98-35
Сыктывкар (8212)25-95-17
Тамбов (4752)50-40-97
Тверь (4822)63-31-35

Узбекистан +998(71)205-18-59

Тольятти (8482)63-91-07
Томск (3822)98-41-53
Тула (4872)33-79-87
Тюмень (3452)66-21-18
Улан-Удэ (3012)59-97-51
Ульяновск (8422)24-23-59
Уфа (347)229-48-12
Хабаровск (4212)92-98-04
Чебоксары (8352)28-53-07
Челябинск (351)202-03-61
Череповец (8202)49-02-64
Чита (3022)38-34-83
Якутск (4112)23-90-97
Ярославль (4852)69-52-93

Киргизия +996(312)96-26-47