

# Поршневые кольца

## Технические характеристики

По вопросам продаж и поддержки обращайтесь:

Алматы (727)345-47-04  
Ангарск (3955)60-70-56  
Архангельск (8182)63-90-72  
Астрахань (8512)99-46-04  
Барнаул (3852)73-04-60  
Белгород (4722)40-23-64  
Благовещенск (4162)22-76-07  
Брянск (4832)59-03-52  
Владивосток (423)249-28-31  
Владикавказ (8672)28-90-48  
Владимир (4922)49-43-18  
Волгоград (844)278-03-48  
Вологда (8172)26-41-59  
Воронеж (473)204-51-73  
Екатеринбург (343)384-55-89

Иваново (4932)77-34-06  
Ижевск (3412)26-03-58  
Иркутск (395)279-98-46  
Казань (843)206-01-48  
Калининград (4012)72-03-81  
Калуга (4842)92-23-67  
Кемерово (3842)65-04-62  
Киров (8332)68-02-04  
Коломна (4966)23-41-49  
Кострома (4942)77-07-48  
Краснодар (861)203-40-90  
Красноярск (391)204-63-61  
Курск (4712)77-13-04  
Курган (3522)50-90-47  
Липецк (4742)52-20-81

Магнитогорск (3519)55-03-13  
Москва (495)268-04-70  
Мурманск (8152)59-64-93  
Набережные Челны (8552)20-53-41  
Нижний Новгород (831)429-08-12  
Новокузнецк (3843)20-46-81  
Ноябрьск (3496)41-32-12  
Новосибирск (383)227-86-73  
Омск (3812)21-46-40  
Орел (4862)44-53-42  
Оренбург (3532)37-68-04  
Пенза (8412)22-31-16  
Петрозаводск (8142)55-98-37  
Псков (8112)59-10-37  
Пермь (342)205-81-47

Ростов-на-Дону (863)308-18-15  
Рязань (4912)46-61-64  
Самара (846)206-03-16  
Санкт-Петербург (812)309-46-40  
Саратов (845)249-38-78  
Севастополь (8692)22-31-93  
Саранск (8342)22-96-24  
Симферополь (3652)67-13-56  
Смоленск (4812)29-41-54  
Сочи (862)225-72-31  
Ставрополь (8652)20-65-13  
Сургут (3462)77-98-35  
Сыктывкар (8212)25-95-17  
Тамбов (4752)50-40-97  
Тверь (4822)63-31-35

Тольятти (8482)63-91-07  
Томск (3822)98-41-53  
Тула (4872)33-79-87  
Тюмень (3452)66-21-18  
Ульяновск (8422)24-23-59  
Улан-Удэ (3012)59-97-51  
Уфа (347)229-48-12  
Хабаровск (4212)92-98-04  
Чебоксары (8352)28-53-07  
Челябинск (351)202-03-61  
Череповец (8202)49-02-64  
Чита (3022)38-34-83  
Якутск (4112)23-90-97  
Ярославль (4852)69-52-93

Россия +7(495)268-04-70

Казахстан +(727)345-47-04

Беларусь +(375)257-127-884

Узбекистан +998(71)205-18-59

Киргизия +996(312)96-26-47

эл.почта: [men@nt-rt.ru](mailto:men@nt-rt.ru) || сайт: <https://mahle.nt-rt.ru/>



<b>Technical service</b> .....	Page
<b>Piston ring technology</b> .....	Page
<b>Steel compression rings</b> .....	Page
<b>HV385 thermal spray</b> .....	Page
<b>Piston ring nomenclature</b> .....	Page
<b>Piston nomenclature</b> .....	Page
<b>Piston ring terminology - compression rings</b> .....	Page
<b>Top compression ring</b> .....	Page
<b>Compression ring evolution</b> .....	Page
<b>Second ring</b> .....	Page
<b>Piston ring terminology - oil rings and assemblies</b> .....	Page
<b>Oil control ring</b> .....	Page
<b>Compression ring and oil ring design illustrations</b> .....	Page
<b>Performance ring descriptions</b> .....	Page
<b>Ring selection guide</b> .....	Page
<b>Ring gap recommendation guide</b> .....	Page
<b>Ring installation procedures</b> .....	Page
<b>Nitro-fueled piston rings</b> .....	Page
<b>Claimer race applications</b> .....	Page
<b>PC479 Fire-Power™ piston ring sets</b> .....	Page
<b>Gas nitride steel ring sets</b> .....	Page
<b>Plasma-moly steel ring sets</b> .....	Page
<b>Plasma-moly ductile ring sets</b> .....	Page
<b>Metric ring sets</b> .....	Page
<b>Ring codes, definitions and types</b> .....	Page
<b>Compression ring and oil ring design illustrations</b> .....	Page
<b>Open stock rings</b> .....	Page
<b>Performance ring set interchange listing</b> .....	Page
<b>Measurement equivalents</b> .....	Page

# High Velocity Oxygen Fueled Thermal Spray Coating (HV385)

MAHLE Performance HV385 High Velocity Oxygen Fueled (HVOF) Thermal Spray Face Coating is designed, engineered, and manufactured to withstand the extreme punishment of today's high RPM naturally aspirated, turbocharged, supercharged and nitrous oxide assisted engines.

The MAHLE patented HV385 ring face coating is applied using an ultra-high temperature thermal spray process, fueled by pure oxygen and RP1 jet fuel. The resulting jet engine-like combustion event accelerates the molten material to supersonic speeds, spraying onto the face of the ring. This high temperature, high velocity stream

of molten alloy face coating ceramic/metallic material creates a very dense and extremely well bonded coating on the ring face that outlasts even the most demanding operating conditions. Additionally, the HV385 thermal spray face coating provides unmatched strength, scuff resistance, and overall durability – not obtainable by any other piston ring face coating, or surface treatment in the industry today.

The HV385 thermal spray face coated top rings feature micro-polished side and face sealing surfaces, minimizing friction, ensuring quick seating, and providing a uniform barrel face profile.

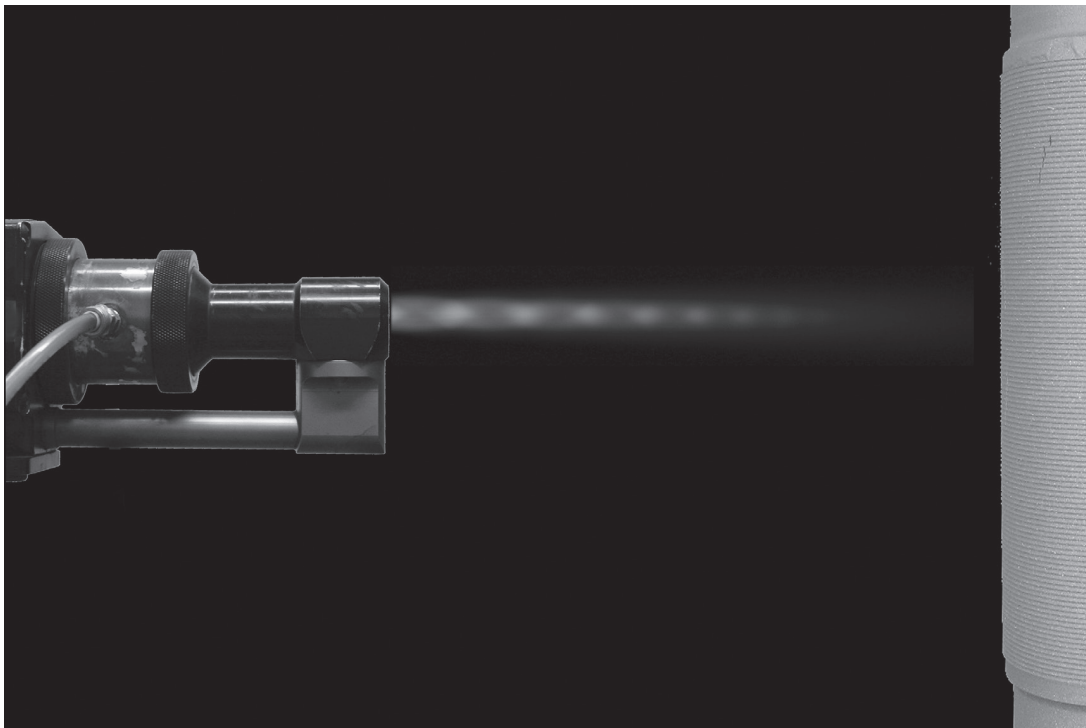

*The MAHLE high velocity oxygen fueled thermal spray gun applying the patented HV385 ring face MAHLE coating.*

## Relative Wear in Gasoline Engines (By Ring Face Treatment)

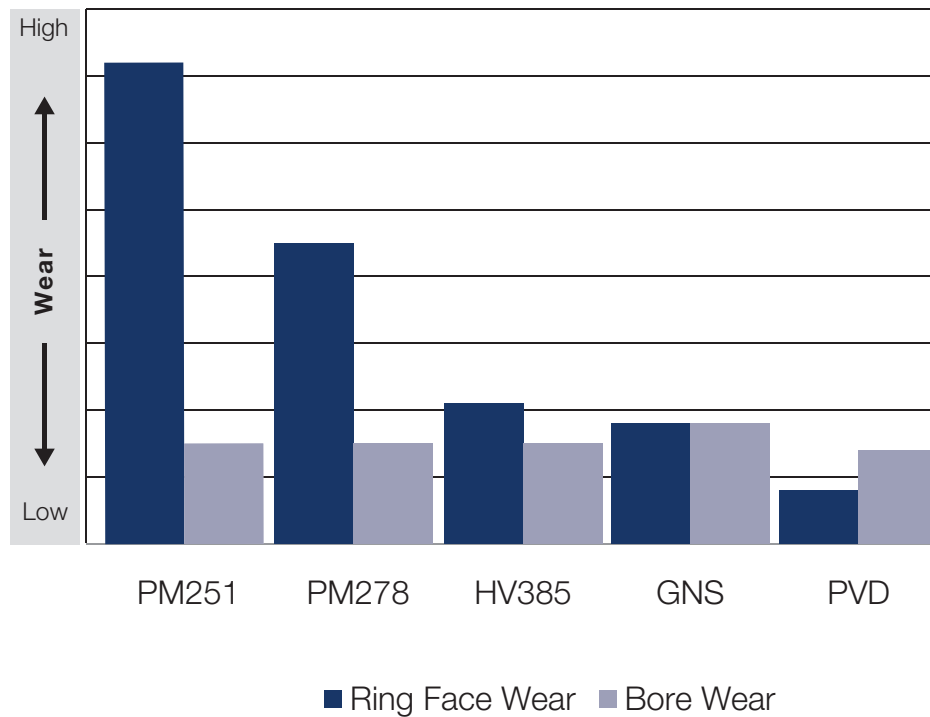

Balancing piston ring face wear and cylinder bore wear is necessary to achieve the long service life expectations of today's high performance racing engines. **The MAHLE HV385 thermal spray face coating improves ring face wear by over 50% without increasing bore wear.**

## Relative Coating Strength vs. Scuff Resistance

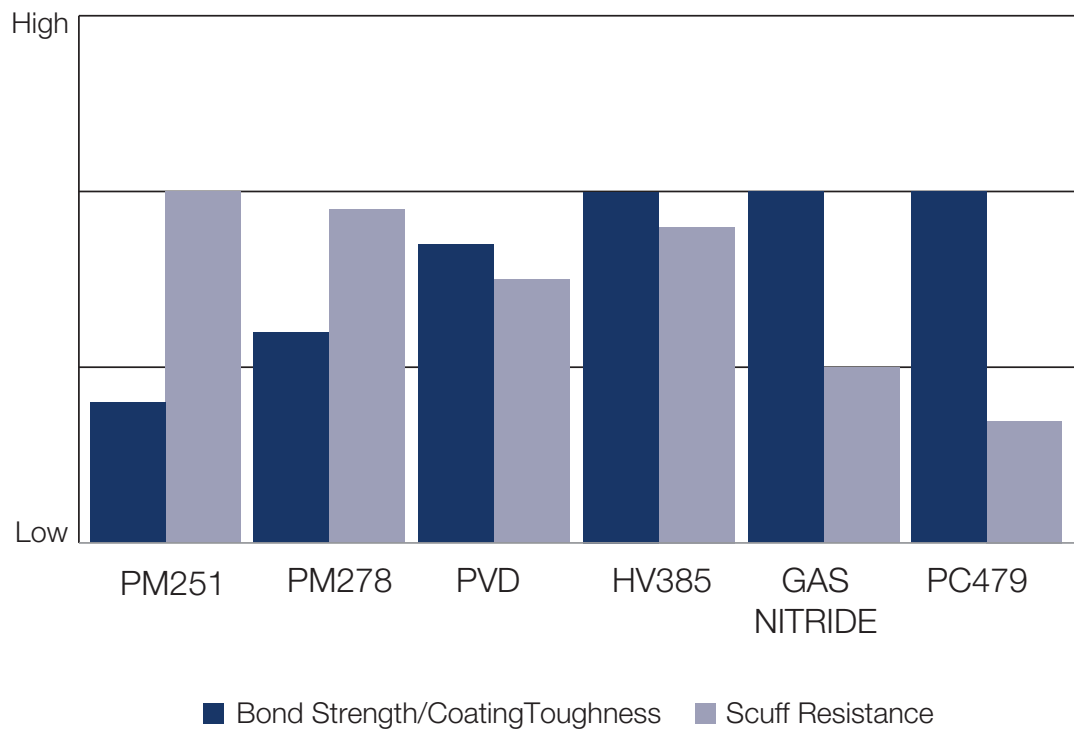

High temperature, high firing pressure, and minimal lubrication operating conditions demand a delicate balance of piston ring material strength, and hardness, without creating a ring so tough it wears, or scuffs the cylinder bore and destroys the sealing surface. **The MAHLE HV385 thermal spray face coating uses a patented blend of hard self-lubricating metal and ceramic alloys, along with an aerospace inspired application process, that work together to create a ring face coating with overall strength and toughness comparable to heat treatments like gas nitride, PVD and DLC, yet scuff resistant to the cylinder wall like moly based plasmas.**

## Frictional Characteristics - Top Ring Face Coatings

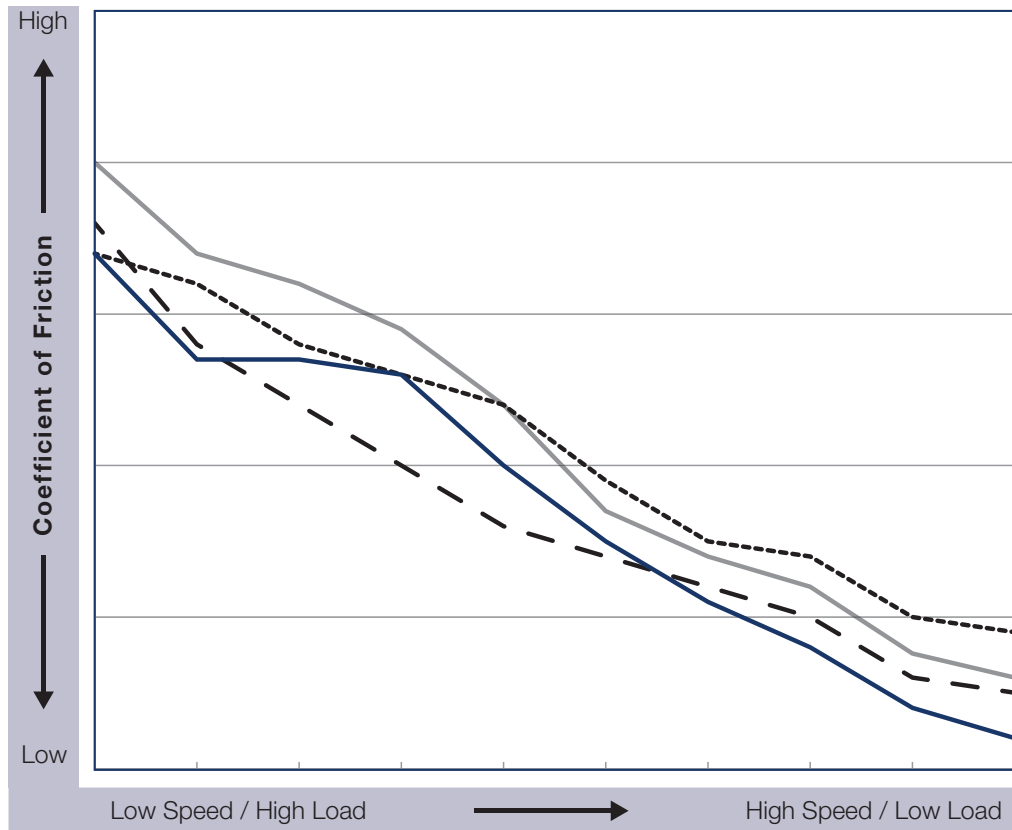

-----PM251/278 Plasma    — Nitride    - - PVD    — HV385 with MICROPOLISHED FACE

Coefficient of friction changes as surface speed and load change. In the graph above, the left side of the graph depicts a low speed / high load condition piston rings see approaching, and leaving TDC on the firing stroke. The right side of the graph depicts a high speed / low load condition piston rings see as piston speeds reach their peak at mid-stroke of each cycle, where the ring face rides up on the hydro-dynamic wave of oil film. **The MAHLE patented HV385 thermal spray face coating, with micro-polished face, is the only face coating showing the lowest coefficient of friction in both operating conditions.**

**Top Compression Rings:** The primary job of the top ring is compression seal. The top ring plays a minor part in oil control. Since the top compression ring is the closest to the combustion chamber, it gets the brunt of the heat, protecting the second and oil ring to a greater extent.

Positive twist-barrel faced top compression rings are the most popular for performance applications. The barrel face provides instantaneous break-in, which is important for racing engines, and maintains contact with the cylinder wall as the piston rocks slightly at TDC and BDC.

Dykes top rings are offered for various sizes and are used primarily in drag racing. The step cut on the top side of the dykes ring helps with gas loading and is favored with many engine builders all the way through top fuel and funny car teams.

**Second compression rings:** Second rings function primarily as an oil control device. 80-90% oil control and about 10-20% compression control is the norm. The two common design second rings are a reverse-twist, taper faced (RBT) and a hook groove (THG), sometimes called a Napier ring. The THG Napier ring is very common in performance ring sets.

An inside bevel causes torsional twist in the ring. The twist acts in a manner that prevents oil migration up and behind the second ring. The taper face scrapes oil off the cylinder wall, providing oil control.

THG second rings also have torsional twist caused by not a bevel on the ID but the machining of the hook groove on the OD. The purpose is the same, limiting oil migration behind the ring. THG second rings offer improved oil control than RBT rings.

**Oil rings:** All MAHLE Performance rings use the CP-20™ design, three-piece oil ring. A technical description of this ring can be found under oil control ring on page 17 of this catalog.

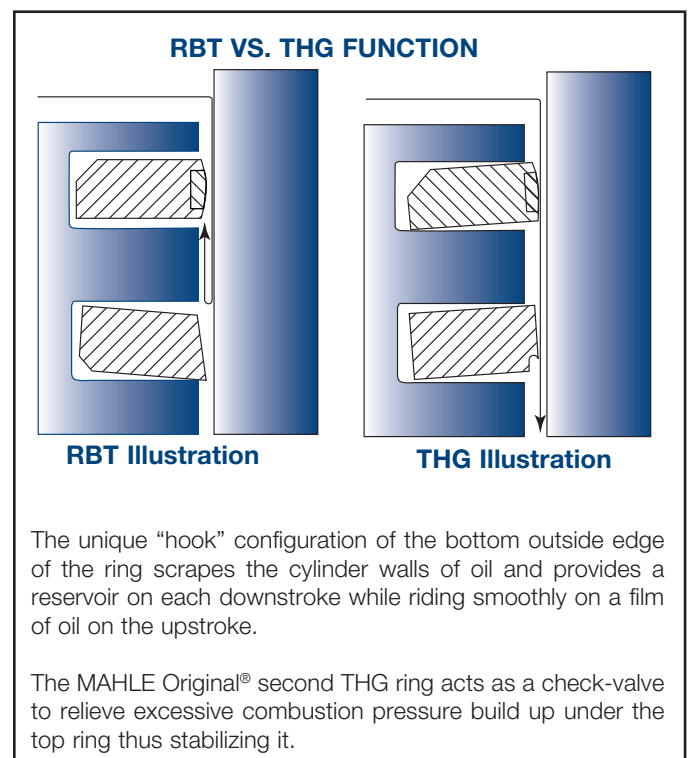
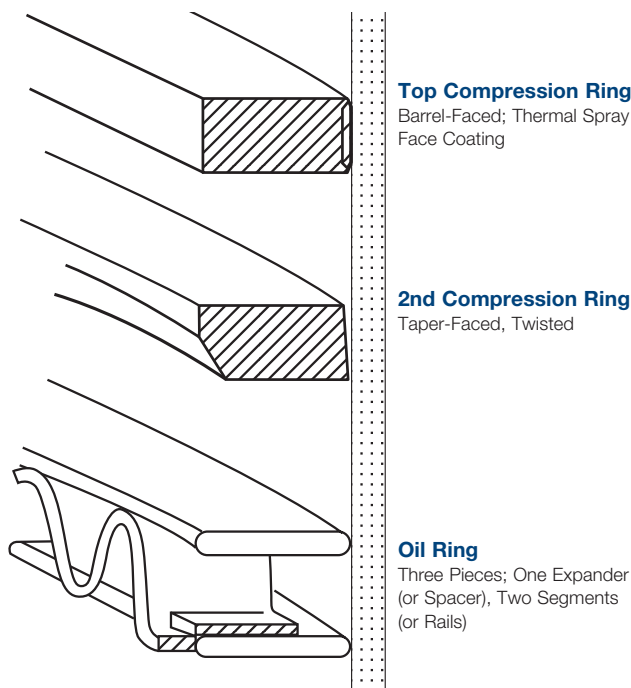

**Piston crown:** The very top of the piston, the part that forms the bottom of the combustion chamber. It may be flat, domed or dished depending on the motor.

**Groove or ring groove:** There is one groove for each ring on the piston, usually top ring groove, second ring groove and oil ring groove. Groove radius and ring ID radius have to match and they promote reduced gas loss behind the ring.

**Radial back clearance:** The clearance remaining between the back of the ring when installed on the piston, when the ring face is flush with piston ring land.

**Side clearance:** The vertical clearance remaining in the piston ring groove after the ring is installed.

**Lands or ring lands:** Piston material above and below the ring grooves. Lands support the ring and may be modified by the piston manufacture to promote ring seal.

**Drain holes or drain slots:** Usually found at the back of the oil ring groove to allow oil which has been scraped off the cylinder wall to drain back to the crankcase.

**Piston skirt:** The part of the piston below the oil ring groove. The skirt provides piston stability, although most racing engines have very little in the way of a piston skirt. Reasons include the need to clear the counterweights on the crank, especially on stroker motors, and to reduce piston mass and inertial loads on the piston.

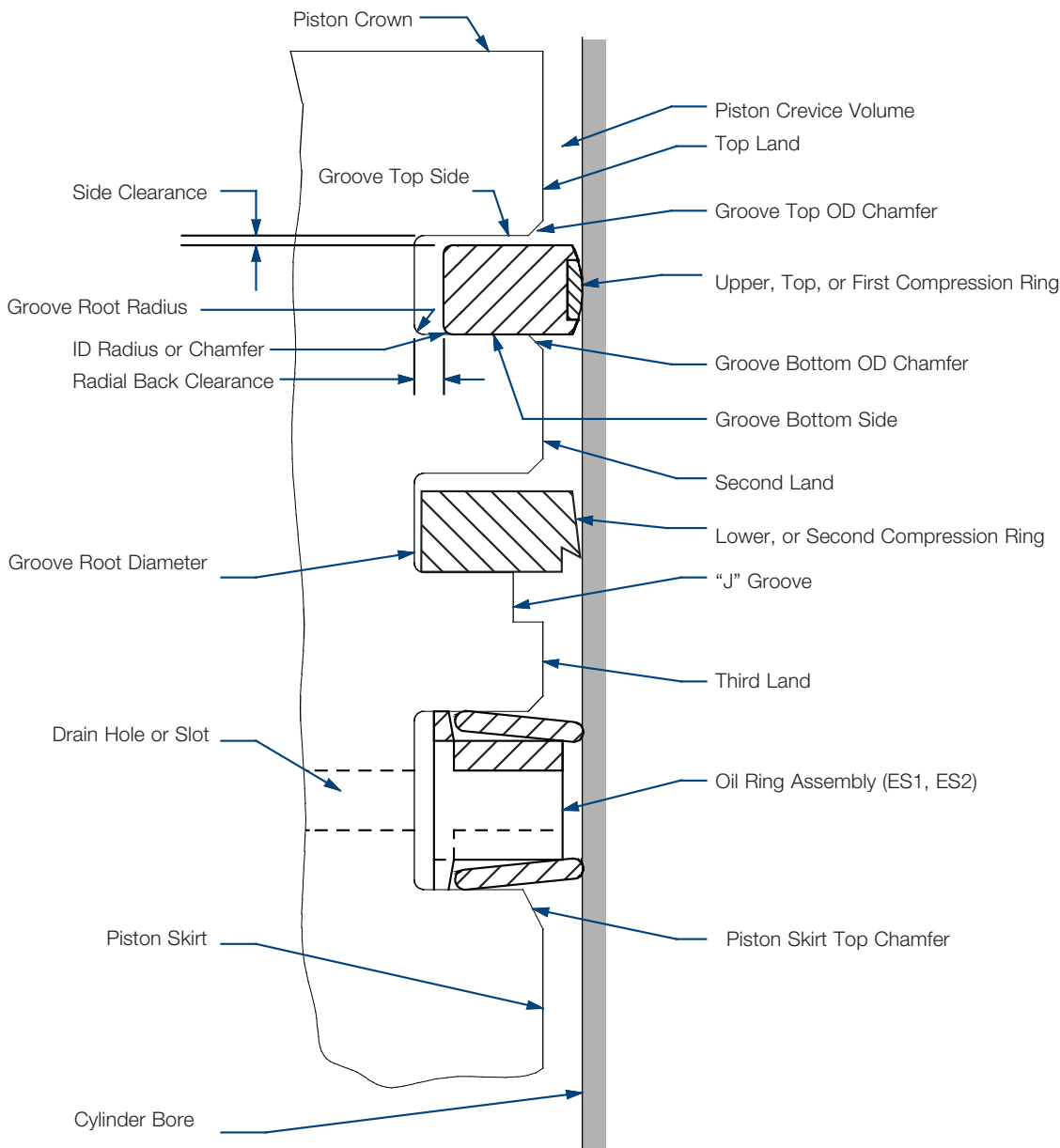

## Radial Wall Thickness

This is the ring measured from the front face touching the cylinder wall to the back or inside face of the ring. “D-wall” is the standard automotive thickness and it’s calculated by bore diameter divided by 22. For example: 4.125” bore divided by 22 is .187” radial wall thickness.

## Reduced Radial Wall Thickness

Sometimes referred to as “back-cut”, these are compression rings with less than “D-wall” thickness. Reasons for reduced radial wall include: creating stronger pistons, reducing tension load on the cylinder wall and allowing the ring to be moved up on the piston, reducing crevice volume.

## Axial Height

Measured from one side face to the other, expressed in fractional sizes like 1/16”, decimal sizes like .043” or metric sizes like 1.5MM. Generally speaking, smaller ring thickness means less mass. Less mass also means less inertia to overcome when the ring reaches TDC or BDC and has to reverse direction in the cylinder.

## Face

The part of the ring facing or contacting the cylinder wall. Virtually all racing top rings are made with a “barrel face” design. Barrel faced top rings provide the following advantages: Rapid break-in and continual contact with the cylinder wall when piston rocks at TDC. Second compression rings can be “twisted-taper-faced” or THG napier designs, depending on the intended application and size desired.

## Gap

Usually measured 1/2” down in a cylinder of desired size, gap is the space between the ends of the compression rings. See page 21 for gap recommendations.

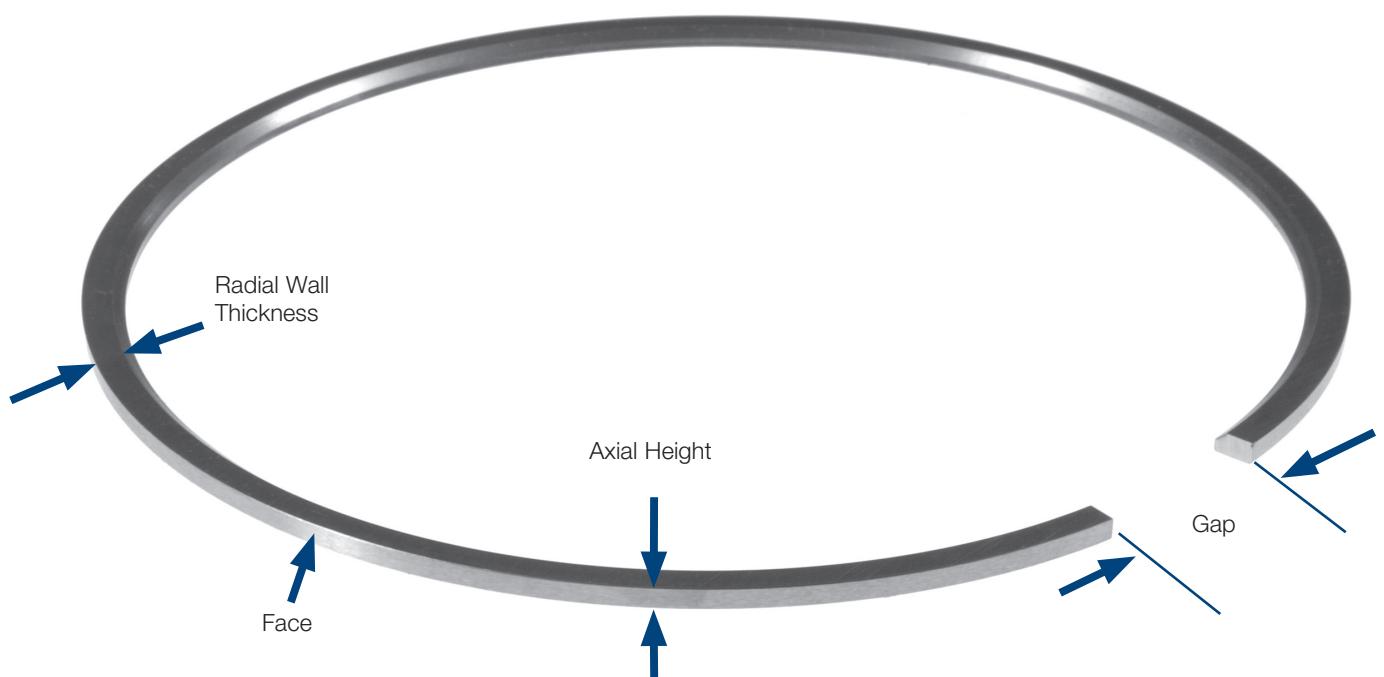

MAHLE Performance compression rings are engineered to provide the best possible sealing for maximum power output. To meet the needs of today's harsh performance environment MAHLE Performance offers compression rings in multiple materials, widths and types. Material choices include cast iron, ductile iron, and steel.

## Cast Iron

- Clainer sets feature a cast iron or cast iron plasma-moly top compression ring

## Ductile Iron

- Grey Iron and ductile iron work well in moderate performance applications
- Ductile-chrome top rings can withstand operating temperatures up to 600° F. Dusty or highly abrasive environments, like off-road racing, are ductile-chrome's strength
- Ductile-Plasma rings can withstand higher operating temperatures and marginal lubrication environments better than ductile-chrome

## PC479 – Hardened Ductile Iron

- PC479 – Hardened ductile iron goes through an additional hardening process that provides a stronger surface hardness, and overall toughness, which allows the piston ring to run against most bore surfaces without additional face coating
- Used in power adder applications where operating conditions exceed the capabilities of a common face coated ring

## GNS - Gas Nitrided Stainless Steel

- Provides additional hardness and scuff resistance over PC479 for high end power adder applications

## SAE 9254 Steel

- SAE 9254 Steel provides unequaled strength and fatigue resistance which extends ring life, minimizes side wear, and reduces ring breakage
- SAE 9254 Steel's overall strength allows for thinner radial wall designs that reduce ring flutter, and improve dynamic sealing, which extends the engine's usable RPM range
- MAHLE HV385 patented thermal sprayed face coating and MAHLE Performance SAE 9254 compression rings exceed the strength, scuff resistance, and overall durability levels demanded by today's ultra-high output performance applications

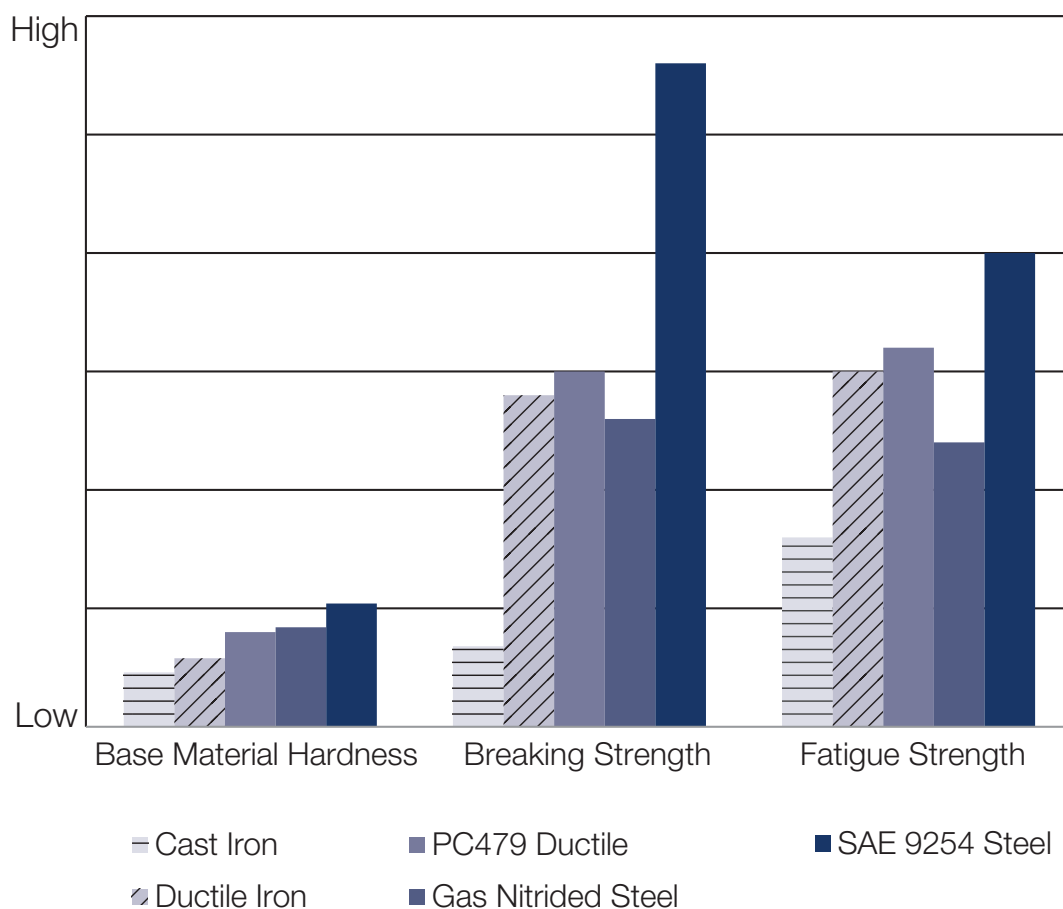

The increasing RPM and cylinder pressure of today's high performance racing engines demand the strongest and lightest piston ring components. **The MAHLE SAE 9254 steel piston ring material features outstanding fatigue resistance as well as resistance to breakage creating a piston ring that is far superior to any other piston ring material in the industry.**

ADVANTAGES	DISADVANTAGES
<b>1920</b>	
<b>Typical Compression Ring Widths: 3/32" / .0935"</b>	
Adequate strength with existing materials technology	Heavy, relatively high tension and friction to achieve static sealing requirements
<b>1960</b>	
<b>Typical Compression Ring Widths: 5/64" / .078" / 2.0MM</b>	
Improved materials and straighter cylinders allowed for less static tension to achieve proper sealing. Reduced piston ring mass, from smaller width and cross section allowed for higher RPM stability.	Slight reduction in durability due to reduced running surface area. Chrome and plasma-moly anti-wear face coatings used to increase ring life, and durability.
<b>1965</b>	
<b>Typical Compression Ring Widths: 1/16" / .0625"</b>	
High strength/ductile iron improved the piston ring's ability to hold tension, and resist unwanted twist at the higher operating temperatures and loads. Reduced piston ring mass allowed for improved high RPM stability.	Reduction in durability due to reduced running surface area. Plasma-moly or chrome anti-wear face coatings became necessary to maintain overall durability.
<b>1975</b>	
<b>Typical Compression Ring Widths: .043" / 1.1MM</b>	
Smaller cross section and reduced piston ring mass allowed for additional ring stability at higher RPM's	Noticeable reduction in durability due to reduced running surface area. Relatively thin cross section pushed the limit of ductile iron's ability to resist twist and hold tension in high temperature/ high load applications. Plasma-moly face coatings were used in the majority of applications to improve overall ring durability.
<b>1982</b>	
<b>Typical Compression Ring Widths: .0586" / 1.5MM – Grey Iron and Steel</b>	
Reduced piston ring mass, over .078" wide rings, allowed for additional stability at higher RPM's	Reduction in durability due to reduced running surface area. New developments in anti-wear face coatings, PF273, PF278, and flash chrome on 2nd rings improved ring life expectancy.
<b>2005</b>	
<b>Typical Compression Ring Widths: .047" / 1.2MM – 9254 Steel</b>	
The added strength of steel, over ductile iron, and the use of PF278 - Plasma, improve the ring's scuff resistance, torsional rigidity, and overall durability. The significantly reduced cross section and piston ring mass, extend the usable RPM range and improve ring stability, and sealing.	Reduced ring cross section requires reduced ring-to-groove side clearance, and optimized lower land size, flatness, and angularity achieve best results.
<b>2016</b>	
<b>Typical Compression Ring Widths: .039" / 1.0MM – 9254 Steel</b>	
Further reduction in cross section and piston ring mass, extend the usable RPM range without loss of ring stability. The addition of HV385 - Thermal Spray Face Coating, adds coating strength and durability well above any previous design.	Reduced ring cross section requires reduced ring-to-groove side clearance, and optimized lower land size, flatness, and angularity achieve best results.

The primary function of the second ring is to control oil. MAHLE Performance piston rings offer the tapered hook groove (THG) second ring that provides superior oil control, improved combustion gas management, improved top ring stability, and improved sealing. Combined, these qualities provide the performance enthusiast with the best possible oil control and least amount of power loss in any performance second ring.

Back pressure buildup from combustion gasses leaking past the top ring can cause the top ring to float, breaking the combustion seal and reducing power. The MAHLE Performance second ring acts as a check valve to relieve the excessive combustion pressure build up under the top ring,

thus stabilizing it. The unique hook configuration of the outside bottom edge scrapes the cylinder walls of oil, and provides a reservoir on each down-stroke, while riding smoothly on a film of oil on the upstroke.

MAHLE Aftermarket continues to lead the Industry with the introduction of SAE 9254 Napier design, THG second rings. Just as with top rings, the overall strength and toughness of SAE 9254 steel allows for thinner and lighter-design second rings, that conform better to the cylinder wall, and actually improve oil scraping efficiency, while reducing friction, and parasitic loss.

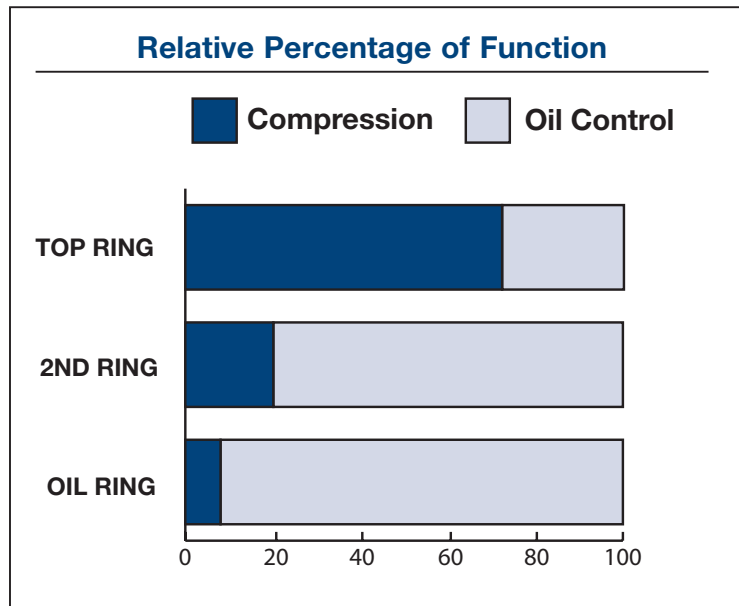

The primary function of the second ring is to control oil as much as 80%. The second ring is also used in compression control up to 20%.

## Rails or segments

Two flat steel pieces with chrome plated faces, they do the scraping and sealing provided by the oil ring. Gap would be measured the same way as compression ring gap.

## Expander or spacer

This piece does several things. Allows for oil drain-back, locates the top and bottom rails and ultimately dictates oil ring tension.

Note: All performance oil rings sold by MAHLE Performance are of three-piece design, that is to say, they have a top and bottom rail or segment and an expander.

## Segment width

The thickness of a rail or segment measured from top to bottom.

Note: The nominal assembled width is the dimension listed in the catalog, for instance, 3.0MM, 1/8" and 3/16" are common assembled oil ring widths.

## Tab angle

Most of the competition use a tab angle of 90 degrees. MAHLE makes use of a better design, CP-20™, which utilizes an angle of 20 degrees. The CP-20 oil ring allows the rail or segment to push up the 20 degree angle until it contacts the oil ring land both top and bottom. The net result is better side-seal and lower oil consumption than conventional rings.

## Assembled radial thickness

You'll see both standard and reduced wall thicknesses listed. Wall thickness is dictated by piston manufacturer's specs and engine builders' desire for reduced mass and tension.

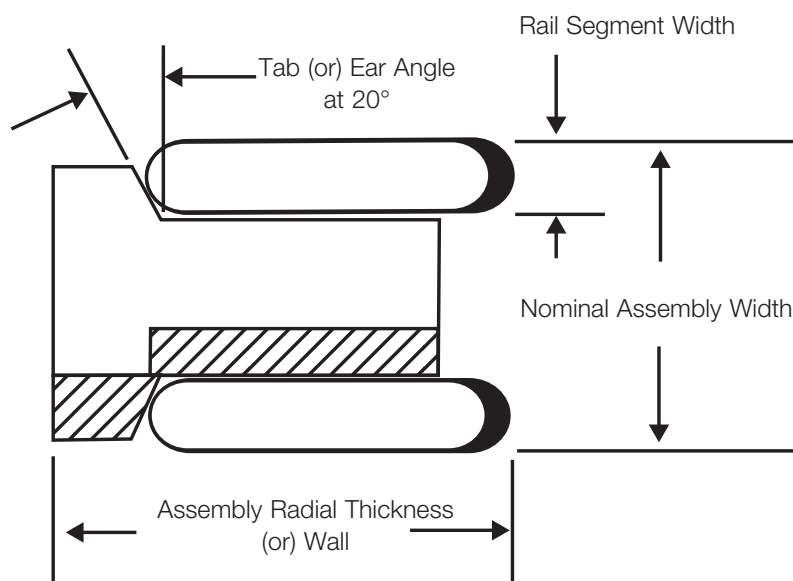
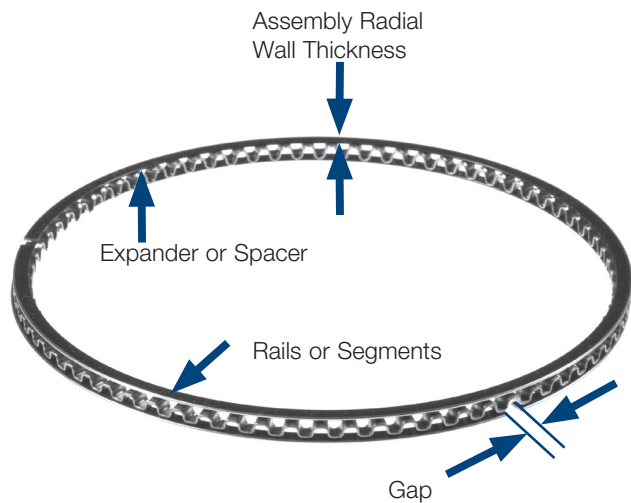

MAHLE Performance CP-20™ oil control rings were designed to provide superior oil control in all performance applications. MAHLE Performance oil rings utilize the exclusive 20° ear angle for the best possible side seal in the piston oil ring groove. The unique ChemPolish™ process improves oil drain back. The CP-20 design simplifies installation by eliminating wire latches and or nylon blocks, while the low deflection rate assures an easy installation.

Each CP-20 oil ring assembly is designed around a specific bore diameter to provide the least amount of internal engine friction while providing the best possible oil control. These oil rings are available in four tensions to suit the needs of all racers and performance enthusiasts. See page 20 for ring selection guide.

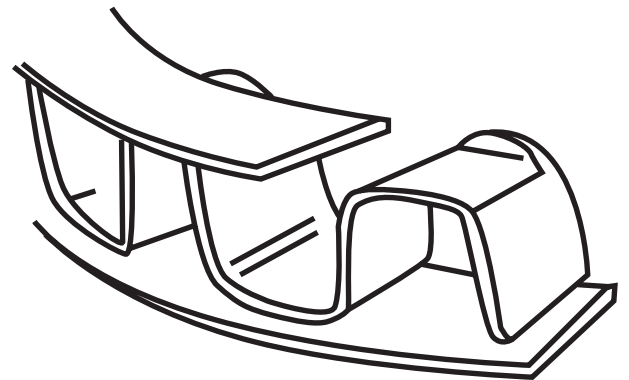



### Oil Ring Scraping Efficiency

Oil scraping efficiency is directly proportional to the radial wall of the rail, and the tension of the assembly. Using the typical three-piece oil ring of the mid-1970's as our baseline, the rail wall vs. tension combinations would look like this:

Time of use in O.E. Engines	Radial Wall of Rail	Tension	Nominal Width	Documented Oil Consumption
1970	.153" - .168"	20 lbs.	.1875"	1,500 - 3,000 miles per Qt.
1985	.123" - .136"	16-18 lbs	4.0 mm (.1575")	3,000-4,000 miles per Qt.
1995	.103" - .110"	10 -14 lbs.	3.0 mm (.118")	4,000-5,000 miles per Qt.
2005	.093" - .098"	9-10 lbs.	2.5 mm (.0984")	5,000 - 7,500 miles per Qt.
2010	.079" - .088"	7-9 lbs.	2.0 mm (.0787")	7,500 - 10,000 miles per Qt.

**MAHLE Performance oil ring assemblies are designed to achieve optimum level of oil control for today's low windage/ wet sump, performance applications.**

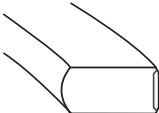
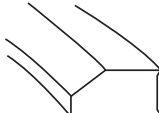
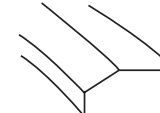
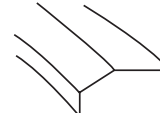
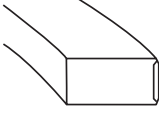
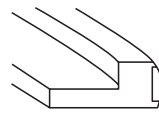
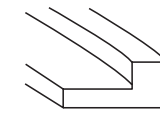
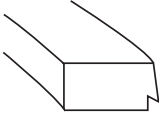
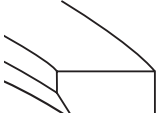
Over 40 years of oil ring design and evolution has shown a 50% reduction in tension and oil ring assembly radial wall, while also achieving a 300% improvement in oil control. The corresponding reduction in parasitic loss due to reduced tension and friction translates directly to increased horsepower.

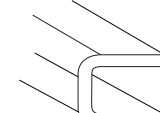
<p><b>RF-13PF</b> Radius Back Steel</p>	<p><b>BR-18PF / BR-13PF</b> Twisted Barrel Faced</p>	<p><b>BR-12NG</b> Positive Twist Gas Nitrided Stainless Steel</p>	<p><b>BR-19</b></p>
			
<p><b>RF-13U</b> Non-Twisted Barrel Faced</p>	<p><b>PB-18PF</b> Dykes</p>	<p><b>PB-18 / PB-19</b> Dykes</p>	
			
<p><b>THM-13 / THM-10 / THG-10</b> Taper Hook Groove (Napier)</p>	<p><b>RBT-10</b> Reverse-Twist Taper Faced</p>	<p><b>CP-20™</b></p>	<p><b>U-Flex</b></p>
			

**The following are descriptions of the types of performance rings found in this catalog:**

## **Claimer Race Applications**

MAHLE claimer performance piston ring sets are engineered for oval track claimer series engines. These economy performance ring sets feature many of the same benefits as our race proven premium sets at an economical price. Positively Twisted 5/64" or 1/16" top rings provide outstanding high RPM sealing in a choice of plain cast iron or plasma-moly face coatings. These sets also utilize a 5/64" RBT or 1/16" THG second ring which provides unmatched oil control in race conditions. Oil rings are also utilized in standard and low tension for optimum power output.

## **PC479 Fire-Power™ Ring Sets**

MAHLE Performance Fire-Power™ piston ring sets are engineered to withstand the punishment of today's high powered nitrous oxide injected, turbocharged and supercharged race applications. PC479 compression rings provide superior ring durability, stable radial tension, superior combustion sealing and oil control, while protecting the cylinder walls. All these benefits net additional horsepower while extending engine life. MAHLE Performance Fire-Power™ rings can be purchased in boxed engine sets as well as open stock to meet your performance requirements.

## **Gas Nitride Ring Sets**

MAHLE Performance gas nitride steel (GNS) piston ring sets are engineered to withstand the extreme punishment of today's high compression naturally aspirated; nitrous oxide injected, turbocharged and supercharged race engines. GNS ring sets provide overall strength only offered by a steel ring as well as provide high conformability, reduced piston ring mass, and less friction. All these benefits net greater horsepower and extend the service life of the engine.

## **Plasma-Moly Steel Ring Sets**

MAHLE Performance plasma-moly steel top rings provide the ultimate in tensile strength, hardness, and fatigue resistance. MAHLE Performance SAE 9254 high-alloy steel is combined with proprietary plasma face coating to extend life, eliminate ring breakage, reduce side wear and minimize groove pound

out problems. The smaller cross-section of the steel ring allows the top ring groove to be closer to the top of the piston. This reduces the crevice volume portion around the top ring land for reduced unburned fuel. Smaller cross-sections mean lower ring mass; this lighter ring design will better tolerate inertial forces and thus seal against the bottom of the ring groove more effectively. The smaller cross-section permitted with higher strength material greatly improves the ability of the ring to conform to cylinder bore distortion often found in today's high output, high RPM engines.

## **Plasma-Moly Ductile Ring Sets**

MAHLE Performance plasma-moly ductile ring sets are designed for the serious racer. These sets feature rings that maximize combustion sealing and minimize frictional losses to increase horsepower and oil control. These sets include reduced radial wall (RRW) compression rings, and oil rings to reduce tension, improve conformability and maximize power output. Ring sets with low and ultra low tension oil rings are not recommended for street use and should utilize a vacuum pump for maximum performance.

## **Chrome Ductile Ring Sets**

MAHLE Performance chrome ductile ring sets are engineered to maximize combustion sealing and minimize frictional losses to increase horsepower and oil control. These sets contain a chrome ductile top ring for superior strength and high RPM combustion sealing. The grey iron RBT or THG second ring provides unmatched oil control. Oil rings are also utilized in standard tension for optimum power output.

Tension Category	Tangential Tension Force	Application Recommendations
<b>2.0MM / 2.5MM</b>		
Ultra-Low	3-5 lbs. (13-22 N.)	Naturally Aspirated Applications, Wet or Dry Sump Oiling System. Crankcase Vacuum System Recommended. Race Only Applications.
Low	6-8 lbs. (27-35 N.)	Naturally Aspirated Applications. Wet or Dry Sump Oiling System. Crankcase Vacuum System Recommended. Primarily Race Applications.
Standard	9-10 lbs. (40-46 N.)	Naturally Aspirated or Power Adder Applications. Wet or Dry Sump Oiling System. Street, Race, or Off-Road Application.
<b>3.0MM / 4.0MM</b>		
Ultra-Low	4-6 lbs. (18-27 N.)	Naturally Aspirated Applications, Wet or Dry Sump Oiling System. Crankcase Vacuum System Recommended. Race only applications.
Low	8-12 lbs. (35-53 N.)	Naturally Aspirated Applications. Wet or Dry Sump Oiling System. Crankcase Vacuum System Recommended. Primarily Race Applications.
Standard	14-18 lbs. (62-80 N.)	Naturally Aspirated or Power Adder Applications. Wet or Dry Sump Oiling System. Street, Race, or Off-Road Application.
<b>3/16"</b>		
Low	9-12 lbs. (40-53 N.)	Naturally Aspirated Applications. Wet or Dry Sump Oiling System. Crankcase Vacuum System Recommended. Primarily Race Applications.
Standard	16-22 lbs. (70-98 N.)	Naturally Aspirated or Power Adder Applications. Wet or Dry Sump Oiling System. Street, Race, or Off-Road Application.
High Tension	23-26 lbs. (102-116 N.)	Power Adder Applications. Wet or Dry Sump Oiling System. Nitro Dragster and Funny Car.

	OE Replacement Sets	310 Claimer Sets	315 Plasma Moly Std Gap Sets	315 Chrome File Fit Sets	315 Plasma Moly File Fit Sets	315 Fire Power File Fit Sets	315 Plasma Moly Carbon Steel File Fit Sets	315 Gas Nitride Steel File Fit Sets
Standard Service	Dark Blue	Light Blue	White	White	White	White	White	White
Light Truck & Towing	Dark Blue	Light Blue	White	White	White	White	White	White
Moderate Performance	Light Blue	Dark Blue	Dark Blue	Light Blue	Dark Blue	Light Blue	Dark Blue	Light Blue
Oval Track Claimer	White	Dark Blue	Dark Blue	Light Blue	Dark Blue	Light Blue	Dark Blue	Light Blue
High Perf. Street Strip	White	Light Blue	Dark Blue	Dark Blue	Dark Blue	Light Blue	Dark Blue	Light Blue
Pro Street & Brackets	White	White	White	Light Blue	Dark Blue	Dark Blue	Dark Blue	Dark Blue
Blower & Nitrous	White	White	White	White	Light Blue	Dark Blue	Light Blue	Dark Blue
Fast Ovals & Drag	White	White	White	Light Blue	Dark Blue	White	Dark Blue	Dark Blue

LEAST PREFERRED	SOMEWHAT PREFERRED	PREFERRED	MOST PREFERRED
-----------------	--------------------	-----------	----------------

Grey Iron, Ductile Iron, SAE 9254 Steel	Ring Width / Axial Height	Recommended Gap Factor (0.000's /in. of Bore Diameter)	4.00" Bore Example (Nominal in .000's)
<b>Top/ Upper Compression Ring (UCR)</b>			
Moderate Performance - Street, Drag Race, Oval Track	.078"/.0625"/1.5MM	.004"	.016"
	.043"/ 1.0MM	.0045"	.018"
Race Only/ Naturally Aspirated - Drag Race, Oval Track	.078"/.0625"/1.5MM	.0045"	.018"
	.043"/ 1.0MM	.005"	.020"
Nitrous Oxide - Street	.078"/.0625"/1.5MM	.005"	.020"
	.043"/ 1.0MM	.0055"	.022"
Nitrous Oxide - Race	.078"/.0625"/1.5MM	.007"	.028"
	.043"/ 1.0MM	.0075"	.030"
Supercharged/ Turbocharged	.078"/.0625"/1.5MM	.007"	.028"
	.043"/ 1.0MM	.0075"	.030"
<b>Second/ Lower Compression Ring (LCR)</b>			
Moderate Performance - Street, Drag Race, Oval Track	.078"/.0625"/1.5MM	.0045"	.018"
	.043"/ 1.0MM	.005"	.020"
Race Only/ Naturally Aspirated - Drag Race, Oval Track	.078"/.0625"/1.5MM	.005"	.020"
	.043"/ 1.0MM	.0055"	.022"
Nitrous Oxide - Street	.078"/.0625"/1.5MM	.0055"	.022"
	.043"/ 1.0MM	.006"	.024"
Nitrous Oxide - Race	.078"/.0625"/1.5MM	.0065"	.026"
	.043"/ 1.0MM	.007"	.028"
Supercharged/ Turbocharged	.078"/.0625"/1.5MM	.006"	.024"
	.043"/ 1.0MM	.0065"	.026"

*Notice: Most of the second ring gap recommendations are larger than the top rings. Recent testing has proven that a larger second ring gap increases the top ring's stability allowing for a better seal. This larger "escape" path prevents inter-ring pressure from building up and lifting the top ring off the piston allowing combustion to get by. Many engine builders have reported lower blow-by and horsepower gains at the upper RPM ranges with the wider second ring gaps. Also, almost every new car made is using this inter-ring pressure reduction method to lower blow-by and emissions and to increase engine output.*

## Ring gap filing procedures:

1. Determine the appropriate gap for your engines bore size and application.
2. Use a manual hand crank style ring grinder or a quality electric ring grinder to properly fit your rings to the cylinder bore.
3. File the ring from the face to the inside diameter of the ring to prevent chipping or damage of the face coating.
4. File only one end of the ring end gap, using the unfiled end as a reference point.
5. Lightly debur the gap edges.

## Ring installation procedures:

1. Check each ring in its corresponding groove to ensure proper axial and radial clearance.
2. Always use a piston ring expander when installing piston rings as spiraling rings into the grooves can damage both the ring and the piston.
3. Lubricate new piston rings with a light assembly oil or motor oil before installation onto the piston.
4. Stagger the end gaps on each compression ring, oil rail and expander.

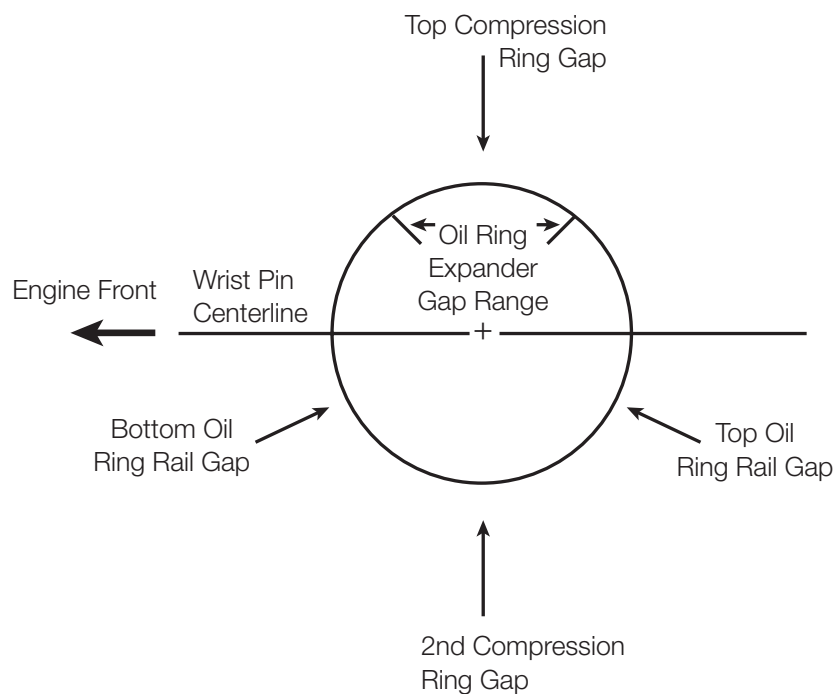

## PC479 Fire-power™ .078 Plasma-Moly Dykes Compression Rings

The MAHLE Performance PC479 Fire Power™ high strength ductile iron ring dramatically improves the torsional rigidity and radial tension stability of the ring with the .078" wide cross section of the dykes, or pressure-backed ring. These features combine to better resist the pressure-twisting phenomenon caused by the high firing pressures of today's nitro-fueled engines. The improved stability provides for increased durability and superior combustion sealing and oil control while the plasma face helps to protect the cylinder walls under these extreme operating conditions.

## .078 Ductile Plasma-Moly Barrel Faced Second Rings

MAHLE Performance .078" ductile plasma-moly barrel-faced second ring provides superior strength, improved torsional rigidity and radial tension along with plasma-moly face to protect the cylinder wall. These features provide a better sealing and more stable second ring over previous designs and materials, resulting in more power and decreased part failure.

## CP-20™ High Tension Nitro Oil Assemblies

MAHLE Performance nitro specific high tension 3/16" chrome oil ring assemblies provide superior oil control with minimal friction loss. All CP-20™ oil assemblies are designed to provide enhanced conformability, utilize the exclusive 20° ear angle for the best possible side seal, and receive the ChemPolish™ process to improve oil drain back. The CP-20 oil ring also simplifies installation by eliminating wire latches and or nylon blocks while maintaining a low deflection rate.

Bore	Axial	Radial	Base Material	Face Coating	Ring Type	Position	Part Number
4.187"	1/16"	.175"	9254 Steel	PVD	BR-13DV	UCR	301-1273B
4.190"	.078"	.170"	PC479	PM251	PB-18PF	UCR	301-0271B
4.190"	.017"	.173"	Ductile Iron	PM251	PB-18PF	UCR	301-0060B
4.190"	.017"	.173"	PC479		PB-18	UCR	301-0236B
4.187"	.010"	.173"	PC479		PB-18	UCR	301-0886B
4.190"	.078"	.193"	Ductile Iron	PM251	BR-18PF	LCR	300-0199B
4.190"	1/16"	.190"	9254 Steel	HV385	BR-13PF	LCR	301-1101B
4.185"	3.0MM	.138"	Stainless Steel	GNS	MCL-42NG-AW (Std)	OCR	303-1000B●
4.190"	3/16"	.201"	Stainless Steel	Chrome	CP-20 (Std)	OCR	303-0133B
4.190"	3/16"	.201"	Stainless Steel	Chrome	CP-20 (High)	OCR	303-0186B



● New Number

★ Discontinued

MAHLE Performance claimer performance piston ring sets are engineered for oval track claimer series engines. These economy performance ring sets feature many of the same benefits as our race proven premium sets at an economical price. Positively twisted 5/64" or 1/16" top rings provide outstanding high RPM sealing in a choice of plain cast iron or plasma-moly face coatings. These sets also utilize a 5/64" RBT or 1/16" THG second ring which provides unmatched oil control in race conditions. CP-20™ oil rings are also utilized in standard and low tension for optimum power output.

#### 1/16", 1/16", 3/16" Plasma-Moly Carbon Steel Low Tension Engine Sets

Part Number	Bore	Top Ring	Radial	Second Ring	Radial	Oil Ring	Radial
310-0012.030	4.030"	301-1016	.190"	302-0112	.170"	303-0158	.201"
310-0012.060	4.060"	301-1020	.190"	302-0116	.170"	303-0161	.201"
310-0011.030	4.155"	301-1105	.190"	302-0131	.170"	303-0171	.201"

#### 1/16", 1/16", 3/16" Plasma-Moly Carbon Steel Standard Tension Engine Sets

Part Number	Bore	Top Ring	Radial	Second Ring	Radial	Oil Ring	Radial
310-0004.030	4.030"	301-1016	.190"	302-0112	.170"	303-0118	.201"
310-0004.060	4.060"	301-1020	.190"	302-0116	.170"	303-0121	.201"

#### 1/16", 1/16", 3/16" Plasma-Moly Ductile Iron Standard Tension Engine Sets

Part Number	Bore	Top Ring	Radial	Second Ring	Radial	Oil Ring	Radial
310-0003.030	4.155"	301-1105	.190"	302-0131	.170"	303-0131	.201"

#### 5/64", 5/64", 3/16" Plasma-Moly Carbon Steel Low Tension Reduced Radial Wall Engine Sets

Part Number	Bore	Top Ring	Radial	Second Ring	Radial	Oil Ring	Radial
310-0014	4.000"	301-0142	.147"	302-0265	.187"	303-0155	.201"
310-0014.030	4.030"	301-0969	.147"	302-0271	.187"	303-0158	.201"
310-0014.040	4.040"	301-0970	.147"	302-0272	.187"	303-0636	.201"

#### 5/64", 5/64", 3/16" Plasma-Moly Grey Iron Low Tension Engine Sets

Part Number	Bore	Top Ring	Radial	Second Ring	Radial	Oil Ring	Radial
310-0013.040	4.165"	301-0152	.193"	302-0248	.193"	303-0172	.201"

**5/64", 5/64", 3/16" Grey Iron Non Coated Standard Tension Engine Sets**

Part Number	Bore	Top Ring	Radial	Second Ring	Radial	Oil Ring	Radial
310-0005.020	4.020"	301-0790	.187"	302-0269	.187"	303-0117	.201"
310-0005.040	4.040"	301-0140	.187"	302-0272	.187"	303-0119	.201"
310-0005.060	4.060"	301-0141	.187"	302-0274	.187"	303-0121	.201"

**5/64", 5/64", 3/16" Plasma-Moly Carbon Steel Standard Tension Reduced Radial Wall Engine Sets**

Part Number	Bore	Top Ring	Radial	Second Ring	Radial	Oil Ring	Radial
310-0006	4.000"	301-0966	.147"	302-0265	.187"	303-0115	.201"
310-0006.020	4.020"	301-0968	.147"	302-0269	.187"	303-0117	.201"
310-0006.030	4.030"	301-0969	.147"	302-0271	.187"	303-0118	.201"
310-0006.040	4.040"	301-0970	.147"	302-0272	.187"	303-0119	.201"
310-0006.060	4.060"	301-0971	.147"	302-0274	.187"	303-0121	.201"

**5/64", 5/64", 3/16" Plasma-Moly Grey Iron Standard Tension Engine Sets**

Part Number	Bore	Top Ring	Radial	Second Ring	Radial	Oil Ring	Radial
310-0008.030	4.155"	301-0151	.193"	302-0247	.193"	303-0131	.201"
310-0008.040	4.165"	301-0152	.193"	302-0248	.193"	303-0132	.201"

MAHLE Performance PC479 Fire-Power™ piston ring sets are engineered to withstand the punishment of today's high powered nitrous oxide injected, turbocharged and supercharged race applications. PC479 compression rings will provide superior ring durability, stable radial tension, superior combustion sealing and oil control, while protecting the cylinder walls. All these benefits will net additional horsepower while extending engine life. MAHLE Performance PC479 Fire-Power™ rings can be purchased in boxed engine sets as well as open stock to meet your performance requirements.

#### 1/16", 1/16", 3/16" PC479 Fire-Power Ductile Iron Standard Tension Engine Sets

Part Number	Bore	Top Ring	Radial	Second Ring	Radial	Oil Ring	Radial
315-0072.005	4.005"	301-0206	.187"	302-0109	.170"	303-0115	.201"
315-0072.035	4.035"	301-0208	.187"	302-0113	.170"	303-0118	.201"
315-0072.045	4.045"	301-0209	.187"	302-0115	.170"	303-0119	.201"
315-0072.065	4.065"	301-0210	.187"	302-0117	.170"	303-0121	.201"
315-0073.005	4.130"	301-0211	.192"	302-0128	.170"	303-0128	.201"
315-0073.035	4.160"	301-0213	.192"	302-0132	.170"	303-0131	.201"
315-0073.045	4.170"	301-0214	.192"	302-0134	.170"	303-0132	.201"
315-0073.065	4.190"	301-0215	.192"	302-0138	.170"	303-0133	.201"
315-0074.035	4.285"	301-0217	.198"	302-0142	.170"	303-0136	.201"
315-0074.065	4.315"	301-0218	.198"	302-0146	.170"	303-0138	.201"
315-0075.035	4.355"	301-0220	.201"	302-1069	.170"	303-0261	.201"
315-0077.005	4.380"	301-0222	.204"	302-1073	.170"	303-0290	.201"
315-0078.005	4.445"	301-0226	.207"	302-0316	.170"	303-0642	.201"
315-0079.005	4.505"	301-0228	.210"	302-0319	.170"	303-0359	.201"
315-0079.035	4.535"	301-0230	.210"	302-0320	.170"	303-0360	.201"
315-0079.065	4.565"	301-0231	.210"	302-0321	.170"	303-0361	.201"
315-0081.005	4.605"	301-0232	.210"	302-0323	.170"	303-0362	.170"

**1/16", 1/16", 3/16" PC479 Fire-Power Ductile Iron High Tension Engine Sets**

Part Number	Bore	Top Ring	Radial	Second Ring	Radial	Oil Ring	Radial
315-0008.035★	4.075"	301-1217	.190"	302-0119	.170"	303-0162	.201"
315-0108.005	4.505"	301-0228	.210"	302-0319	.170"	303-0647	.201"
315-0108.035	4.535"	301-0230	.210"	302-0320	.170"	303-0648	.201"
315-0108.065	4.565"	301-0231	.210"	302-0321	.170"	303-0649	.201"
315-0109.005	4.605"	301-0232	.210"	302-0323	.170"	303-0650	.170"

**.017", 1/16", 3/16" PC479 Fire-Power Ductile Iron Dykes Standard Tension Engine Sets**

Part Number	Bore	Top Ring	Radial	Second Ring	Radial	Oil Ring	Radial
315-0087.005	4.315"	301-0239	.173"	302-0146	.170"	303-0138	.201"

**.017", 1/16", 3/16" PC479 Fire-Power Ductile Iron Dykes High Tension Engine Sets**

Part Number	Bore	Top Ring	Radial	Second Ring	Radial	Oil Ring	Radial
315-0088.005	4.380"	301-0240	.173"	302-1073	.170"	303-0296	.201"
315-0089.005	4.470"	301-0242	.173"	302-1315	.170"	303-0298	.201"
315-0207.005	4.505"	301-0245	.173"	302-0319	.170"	303-0647	.201"

MAHLE Performance gas nitride steel (GNS) piston ring sets are engineered to withstand the extreme punishment of today's high compression naturally aspirated; nitrous oxide injected, turbocharged and supercharged race engines. GNS ring sets provide the overall strength only offered by a steel ring as well as provide high conformability features, reduced ring mass, and less friction. All these benefits will net greater horsepower and extend the service life of the engine.

### **.043", .043", 3.0MM Gas Nitride Steel Ultra Low Tension Reduced Radial Wall Engine Sets**

Part Number	Bore	Top Ring	Radial	Second Ring	Radial	Oil Ring	Radial
315-0014.005	4.380"	300-0180	.204"	302-1073	.170"	303-0278	.201"
315-0017.030	4.155"	301-1192	.157"	302-1260	.135"	303-0013	.153"
315-0017.045★	4.170"	301-1150	.171"	302-1266	.135"	303-0016	.153"

### **.043", .043", 3.0MM Gas Nitride Steel Low Tension Reduced Radial Wall Engine Sets**

Part Number	Bore	Top Ring	Radial	Second Ring	Radial	Oil Ring	Radial
315-0229.005●	4.005"	301-1162	.157"	302-1307	.135"	303-0072	.151"
315-0059.035	4.035"	301-1168	.157"	302-1252	.135"	303-0075	.151"
315-0059.045	4.045"	301-1170	.157"	302-1294	.135"	303-0076	.151"
315-0059.065	4.065"	301-1174	.157"	302-1293	.135"	303-0079	.151"
315-0164.005	4.130"	301-1187	.157"	302-1251	.135"	303-0085	.151"
315-0227.005●	4.135"	301-1188	.157"	302-1248	.135"	303-0087	.151"
315-0164.015	4.140"	301-1189	.157"	302-1265	.135"	303-0087	.151"
315-0164.025	4.150"	301-1147	.157"	302-1313	.135"	303-0089	.151"
315-0164.035	4.160"	301-1193	.157"	302-1257	.135"	303-0090	.151"
315-0164.065	4.190"	301-1199	.157"	302-1296	.135"	303-0240	.154"

### **.043", .043", 3.0MM Gas Nitride Steel Standard Tension Reduced Radial Wall Engine Sets**

Part Number	Bore	Top Ring	Radial	Second Ring	Radial	Oil Ring	Radial
315-0168.035	4.035"	301-1168	.157"	302-1252	.135"	303-0308	.151"
315-0168.045	4.045"	301-1170	.157"	302-1294	.135"	303-0309	.151"
315-0168.065	4.065"	301-1174	.157"	302-1293	.135"	303-0311	.151"
315-0169.005	4.130"	301-1187	.157"	302-1251	.135"	303-0319	.153"
315-0169.015	4.140"	301-1189	.157"	302-1265	.135"	303-0321	.153"
315-0169.035	4.160"	301-1193	.157"	302-1257	.135"	303-0325	.153"

### **.043", .043", 3/16" Gas Nitride Steel Low Tension Reduced Radial Wall Engine Sets**

Part Number	Bore	Top Ring	Radial	Second Ring	Radial	Oil Ring	Radial
315-0140.035	4.035"	301-1168	.157"	302-1252	.135"	303-0158	.201"
315-0140.065	4.065"	301-1174	.157"	302-1293	.135"	303-0161	.201"
315-0163.005	4.130"	301-1187	.157"	302-1251	.135"	303-0168	.201"
315-0163.035	4.160"	301-1193	.157"	302-1257	.135"	303-0171	.201"
315-0228.005●	4.605"	301-1041	.171"	302-1197	.135"	303-0883	.170"

### **.043", .043", 3/16" Gas Nitride Steel Standard Tension Reduced Radial Wall Engine Sets**

Part Number	Bore	Top Ring	Radial	Second Ring	Radial	Oil Ring	Radial
315-0184.035	4.035"	301-1168	.157"	302-1252	.135"	303-0118	.201"
315-0184.045	4.045"	301-1170	.157"	302-1294	.135"	303-0119	.201"
315-0184.065	4.065"	301-1174	.157"	302-1293	.135"	303-0121	.201"
315-0185.035	4.160"	301-1193	.157"	302-1257	.135"	303-0131	.201"

### **.043", 1.5MM, 3.0MM Gas Nitride Steel Low Tension Reduced Radial Wall Engine Sets**

Part Number	Bore	Top Ring	Radial	Second Ring	Radial	Oil Ring	Radial
315-0178.035	4.035"	301-1168	.157"	302-1206	.150"	303-0075	.151"
315-0178.045	4.045"	301-1170	.157"	302-1264	.150"	303-0076	.151"
315-0178.065	4.065"	301-1174	.157"	302-1209	.150"	303-0079	.151"
315-0178.085	4.085"	301-1153	.171"	302-1245	.150"	303-0080	.151"
315-0179.005	4.130"	301-1187	.157"	302-1311	.150"	303-0085	.151"
315-0179.010	4.135"	301-1145	.171"	302-1271	.150"	303-0086	.151"
315-0179.015	4.140"	301-1189	.157"	302-1278	.150"	303-0087	.151"
315-0179.035	4.160"	301-1193	.157"	302-1280	.150"	303-0090	.151"

### **.043", 1.5MM, 3.0MM Gas Nitride Steel Standard Tension Reduced Radial Wall Engine Sets**

Part Number	Bore	Top Ring	Radial	Second Ring	Radial	Oil Ring	Radial
315-0181.025	4.025"	301-1166	.157"	302-1263	.150"	303-0307	.151"
315-0181.035	4.035"	301-1168	.157"	302-1206	.150"	303-0308	.151"
315-0181.045	4.045"	301-1170	.157"	302-1264	.150"	303-0309	.151"
315-0181.065	4.065"	301-1174	.157"	302-1209	.150"	303-0311	.151"
315-0183.005	4.130"	301-1187	.157"	302-1311	.150"	303-0319	.153"
315-0183.010	4.135"	301-1145	.171"	302-1271	.150"	303-0320	.153"
315-0183.015	4.140"	301-1189	.157"	302-1278	.150"	303-0321	.153"
315-0183.035	4.160"	301-1193	.157"	302-1280	.150"	303-0325	.153"

### **1.5MM, 1.5MM, 3.0MM Gas Nitride Steel Standard Tension Reduced Radial Wall Engine Sets**

Part Number	Bore	Top Ring	Radial	Second Ring	Radial	Oil Ring	Radial
315-0240 <sup>•</sup>	4.125"	301-1343	.140"	302-1449	.154"	303-1058	.118"
315-0241 <sup>•</sup>	4.130"	301-1344	.140"	302-1450	.154"	303-1059	.118"

### **.043", 1/16", 3.0MM Gas Nitride Steel Low Tension Reduced Radial Wall Engine Sets**

Part Number	Bore	Top Ring	Radial	Second Ring	Radial	Oil Ring	Radial
315-0154.035	4.035"	301-1168	.157"	302-0113	.170"	303-0075	.151"
315-0154.045	4.045"	301-1170	.157"	302-0115	.170"	303-0076	.151"
315-0155.005	4.130"	301-1187	.157"	302-0128	.170"	303-0085	.151"
315-0155.035	4.160"	301-1193	.157"	302-0132	.170"	303-0090	.151"
315-0107.005	4.565"	301-1100	.171"	302-0902	.212"	303-0361	.201"

**.043", 1/16", 3.0MM Gas Nitride Steel Standard Tension Reduced Radial Wall Engine Sets**

Part Number	Bore	Top Ring	Radial	Second Ring	Radial	Oil Ring	Radial
315-0156.035	4.035"	301-1168	.157"	302-0113	.170"	303-0308	.151"
315-0156.045	4.045"	301-1170	.157"	302-0115	.170"	303-0309	.151"
315-0157.005	4.130"	301-1187	.157"	302-0128	.170"	303-0319	.153"
315-0157.035	4.160"	301-1193	.157"	302-0132	.170"	303-0325	.153"

**.043", 1/16", 3/16" Gas Nitride Steel Low Tension Reduced Radial Wall Engine Sets**

Part Number	Bore	Top Ring	Radial	Second Ring	Radial	Oil Ring	Radial
315-0119.035	4.035"	301-1168	.157"	302-0113	.170"	303-0158	.201"
315-0120.065	4.065"	301-1174	.157"	302-0117	.170"	303-0121	.201"
315-0054.065	4.565"	301-1099	.171"	302-0321	.170"	303-0206	.201"
315-0104.005	4.565"	301-1100	.171"	302-0902	.212"	303-0663	.201"
315-0131.005	4.605"	301-1041	.171"	302-0323	.170"	303-0202	.170"

**.043", 1/16", 3/16" Gas Nitride Steel Standard Tension Reduced Radial Wall Engine Sets**

Part Number	Bore	Top Ring	Radial	Second Ring	Radial	Oil Ring	Radial
315-0120.035	4.035"	301-1168	.157"	302-0113	.170"	303-0118	.201"
315-0120.045	4.045"	301-1170	.157"	302-0115	.170"	303-0119	.201"
315-0084.005	4.130"	301-1187	.157"	302-0128	.170"	303-0128	.201"
315-0084.035	4.160"	301-1193	.157"	302-0132	.170"	303-0131	.201"
315-0084.045★	4.170"	301-1150	.171"	302-0134	.170"	303-0132	.201"
315-0084.065	4.190"	301-1199	.157"	302-0138	.170"	303-0133	.201"
315-0085.005	4.505"	301-1097	.171"	302-0319	.170"	303-0359	.201"
315-0128.005	4.505"	301-1097	.171"	302-0319	.170"	303-0359	.201"
315-0085.035	4.535"	301-1098	.171"	302-0320	.170"	303-0360	.201"
315-0128.065	4.565"	301-1099	.171"	302-0321	.170"	303-0361	.201"
315-0085.065	4.565"	301-1100	.171"	302-0321	.170"	303-0061	.201"
315-0118.005	4.605"	301-1041	.171"	302-0323	.170"	303-0362	.170"
315-0080.025	4.630"	301-1046	.171"	302-0324	.170"	303-0749	.170"

**.043", 1/16", 3/16" Gas Nitride Steel High Tension Reduced Radial Wall Engine Sets**

Part Number	Bore	Top Ring	Radial	Second Ring	Radial	Oil Ring	Radial
315-0110.005	4.505"	301-1097	.171"	302-0319	.170"	303-0647	.201"
315-0110.035	4.535"	301-1098	.171"	302-0320	.170"	303-0648	.201"
315-0110.065	4.565"	301-1100	.171"	302-0321	.170"	303-0649	.201"
315-0111.005	4.605"	301-1041	.171"	302-0323	.170"	303-0650	.170"

MAHLE Performance plasma-moly steel top rings provide the ultimate in tensile strength, hardness, and fatigue resistance. The MAHLE SAE 9254 steel is combined with proprietary plasma face coating to extend life, eliminate ring breakage, reduce side wear and minimize groove pound out problems. The smaller cross-section of the steel ring allows the top ring groove to be moved closer to the top of the piston. This reduces the crevice volume portion around the top ring land for reduced unburned fuel. Smaller cross-sections mean lower ring mass; this lighter ring design will better tolerate inertial forces and thus seal against the bottom of the ring groove more effectively. The smaller cross-section permitted with higher strength material greatly improves the ability of the ring to conform to cylinder bore distortion often found in today's high output, high RPM engines.

### 1.0MM, 1.0MM, 2.0MM HV385 Carbon Steel Standard Tension Reduced Radial Wall Engine Sets

Part Number	Bore	Top Ring	Radial	Second Ring	Radial	Oil Ring	Radial
315-0224.005●	3.771"	301-1258	.143"	302-1361	.136"	303-0956	.113"
315-0225.005●	4.010"	301-1054	.143"	302-1211	.136"	303-0776	.113"
315-0226.005●	4.135"	301-1068	.143"	302-1221	.136"	303-0795	.113"

### 1.2MM, 1.5MM, 3.0MM Plasma-Moly Carbon Steel Ultra Low Tension Reduced Radial Wall Engine Sets

Part Number	Bore	Top Ring	Radial	Second Ring	Radial	Oil Ring	Radial
315-0066.065	4.065"	301-0010	.147"	302-1209	.150"	303-0079	.151"
315-0065.005★	4.130"	301-0017	.147"	302-1311	.150"	303-0008	.153"
315-0065.035★	4.160"	301-0023	.147"	302-1280	.150"	303-0014	.153"
315-0065.045	4.170"	301-0025	.147"	302-1312	.150"	303-0016	.153"

### 1.2MM, 1.5MM, 3.0MM Plasma-Moly Carbon Steel Low Tension Reduced Radial Wall Engine Sets

Part Number	Bore	Top Ring	Radial	Second Ring	Radial	Oil Ring	Radial
315-0064.005	4.005"	301-0002	.147"	302-1262	.150"	303-0072	.151"
315-0064.025	4.025"	301-0004	.147"	302-1263	.150"	303-0074	.151"
315-0064.035	4.035"	301-0006	.147"	302-1206	.150"	303-0075	.151"
315-0064.045	4.045"	301-0007	.147"	302-1264	.150"	303-0076	.151"
315-0064.065	4.065"	301-0010	.147"	302-1209	.150"	303-0079	.151"
315-0067.005	4.130"	301-0017	.147"	302-1311	.150"	303-0085	.151"
315-0067.020	4.145"	301-0020	.147"	302-1272	.150"	303-0089	.151"
315-0067.025	4.150"	301-0021	.147"	302-1279	.150"	303-0089	.151"
315-0067.035	4.160"	301-0023	.147"	302-1280	.150"	303-0090	.151"
315-0067.045	4.170"	301-0025	.147"	302-1312	.150"	303-0238	.154"

### 1.5MM, 1.5MM, 3.0MM Plasma-Moly Carbon Steel Low Tension Reduced Radial Wall Engine Sets

Part Number	Bore	Top Ring	Radial	Second Ring	Radial	Oil Ring	Radial
315-0203.035	4.035"	301-1245	.151"	302-1206	.150"	303-0075	.151"
315-0203.045	4.045"	301-1246	.151"	302-1264	.150"	303-0076	.151"
315-0203.065	4.065"	301-0975	.151"	302-1209	.150"	303-0079	.151"
315-0204.010	4.130"	301-0982	.151"	302-1311	.150"	303-0086	.151"
315-0204.015	4.135"	301-0983	.151"	302-1271	.150"	303-0086	.151"
315-0204.025	4.145"	301-0985	.151"	302-1272	.150"	303-0088	.151"
315-0204.070	4.190"	301-0994	.151"	302-1275	.150"	303-0241	.154"

**1.5MM, 1.5MM, 3.0MM Plasma-Moly Carbon Steel Standard Tension Reduced Radial Wall Engine Sets**

Part Number	Bore	Top Ring	Radial	Second Ring	Radial	Oil Ring	Radial
315-0039.025★	3.576"	301-0108	.155"	302-0210	.166"	303-0515	.151"
315-0206	4.020"	301-0507	.155"	302-1205	.150"	303-0307	.151"
315-0060.030	4.030"	301-0508	.155"	302-1206	.150"	303-0075	.151"
315-0060.035	4.035"	301-1245	.151"	302-1206	.150"	303-0308	.151"
315-0060.045	4.045"	301-1246	.151"	302-1264	.150"	303-0309	.151"
315-0060.065	4.065"	301-0975	.151"	302-1209	.150"	303-0311	.151"
315-0200.015	4.135"	301-0983	.151"	302-1271	.150"	303-0320	.153"

**1.5MM, 1.5MM, 4.0MM Plasma-Moly Carbon Steel Standard Tension Reduced Radial Wall Engine Sets**

Part Number	Bore	Top Ring	Radial	Second Ring	Radial	Oil Ring	Radial
315-0020	4.000"	301-0506	.155"	302-1204	.150"	303-0291	.156"
315-0020.030	4.030"	301-0508	.155"	302-1206	.150"	303-0293	.156"
315-0020.040	4.040"	301-0509	.155"	302-1207	.150"	303-0294	.156"
315-0020.060	4.060"	301-0510	.155"	302-1208	.150"	303-0295	.156"

**1/16", 1/16", 3.0MM Plasma-Moly Carbon Steel Low Tension Engine Sets**

Part Number	Bore	Top Ring	Radial	Second Ring	Radial	Oil Ring	Radial
315-0049.005	4.005"	301-1013	.190"	302-0109	.170"	303-0072	.151"
315-0049.025	4.025"	301-1015	.190"	302-0111	.170"	303-0074	.151"
315-0049.030	4.030"	301-1016	.190"	302-0112	.170"	303-0075	.151"
315-0049.035	4.035"	301-1017	.190"	302-0113	.170"	303-0075	.151"
315-0049.040	4.040"	301-1018	.190"	302-0115	.170"	303-0076	.151"
315-0049.045	4.045"	301-1019	.190"	302-0115	.170"	303-0076	.151"
315-0049.060	4.060"	301-1020	.190"	302-0116	.170"	303-0079	.151"
315-0049.065	4.065"	301-1021	.190"	302-0117	.170"	303-0079	.151"
315-0049.085	4.085"	301-1218	.190"	302-0121	.170"	303-0081	.151"
315-0071	4.125"	301-1102	.190"	302-0127	.170"	303-0085	.151"
315-0071.005	4.130"	301-1103	.190"	302-0128	.170"	303-0085	.151"
315-0071.015	4.140"	301-1214	.190"	302-0292	.170"	303-0087	.151"
315-0071.035	4.160"	301-1106	.190"	302-0132	.170"	303-0090	.151"
315-0141.005	4.505"	301-1120	.190"	302-0319	.170"	303-0092	.151"
315-0142.005	4.605"	301-1125	.190"	302-0323	.170"	303-0095	.151"

● New Number

★ Discontinued

### 1/16", 1/16", 3.0MM Plasma-Moly Carbon Steel Standard Tension Engine Sets

Part Number	Bore	Top Ring	Radial	Second Ring	Radial	Oil Ring	Radial
315-0139.005	4.005"	301-1013	.190"	302-0109	.170"	303-0305	.151"
315-0139.025	4.025"	301-1015	.190"	302-0111	.170"	303-0307	.151"
315-0139.030	4.030"	301-1016	.190"	302-0112	.170"	303-0308	.151"
315-0139.035	4.035"	301-1017	.190"	302-0113	.170"	303-0308	.151"
315-0139.040	4.040"	301-1018	.190"	302-0115	.170"	303-0309	.151"
315-0139.045	4.045"	301-1019	.190"	302-0115	.170"	303-0309	.151"
315-0139.060	4.060"	301-1020	.190"	302-0116	.170"	303-0311	.151"
315-0139.065	4.065"	301-1021	.190"	302-0117	.170"	303-0311	.151"
315-0143.005	4.130"	301-1103	.190"	302-0128	.170"	303-0319	.153"
315-0143.015	4.140"	301-1214	.190"	302-0292	.170"	303-0321	.153"
315-0143.030	4.155"	301-1105	.190"	302-0131	.170"	303-0325	.153"
315-0143.035	4.160"	301-1106	.190"	302-0132	.170"	303-0325	.153"

### 1/16", 1/16", 1/8" Plasma-Moly Carbon Steel Standard Tension Engine Sets

Part Number	Bore	Top Ring	Radial	Second Ring	Radial	Oil Ring	Radial
315-0033.030	4.030"	301-1016	.190"	302-0112	.170"	303-0036	.201"
315-0033.035	4.035"	301-1017	.190"	302-0113	.170"	303-0036	.201"
315-0033.060	4.060"	301-1020	.190"	302-0116	.170"	303-0038	.201"
315-0033.065★	4.065"	301-1021	.190"	302-0117	.170"	303-0038	.201"

### 1/16", 1/16", 3/16" Plasma-Moly Carbon Steel Low Tension Engine Sets

Part Number	Bore	Top Ring	Radial	Second Ring	Radial	Oil Ring	Radial
315-0005.005	4.005"	301-1013	.190"	302-0109	.170"	303-0155	.201"
315-0005.030	4.030"	301-1016	.190"	302-0112	.170"	303-0158	.201"
315-0005.035	4.035"	301-1017	.190"	302-0113	.170"	303-0158	.201"
315-0005.045	4.045"	301-1019	.190"	302-0115	.170"	303-0636	.153"
315-0005.065★	4.065"	301-1021	.190"	302-0117	.170"	303-0161	.201"
315-0005.085	4.085"	301-1218	.190"	302-0121	.170"	303-0163	.201"
315-0004.005	4.130"	301-1103	.190"	302-0128	.170"	303-0168	.201"
315-0004.015	4.140"	301-1214	.190"	302-0292	.170"	303-0169	.201"
315-0004.025	4.150"	301-1104	.190"	302-0130	.170"	303-0170	.201"
315-0004.045	4.170"	301-1107	.190"	302-0134	.170"	303-0172	.201"
315-0002.005★	4.255"	301-1109	.190"	302-0140	.170"	303-0134	.201"
315-0002.035★	4.285"	301-1111	.190"	302-0142	.170"	303-0177	.201"
315-0002.065	4.315"	301-1113	.190"	302-0146	.170"	303-0179	.201"
315-0003.065	4.385"	301-1116	.190"	302-1073	.170"	303-0182	.201"
315-0010.035	4.395"	301-1117	.190"	302-1075	.170"	303-0183	.201"
315-0001.005	4.505"	301-1120	.190"	302-0319	.170"	303-0204	.201"
315-0001.035	4.535"	301-1121	.190"	302-0320	.170"	303-0205	.201"
315-0001.065	4.565"	301-1123	.190"	302-0321	.170"	303-0206	.201"
315-0006.005	4.605"	301-1125	.190"	302-0323	.170"	303-0202	.170"
315-0006.025	4.630"	301-1127	.190"	302-0324	.170"	303-0665	.170"

# PLASMA-MOLY STEEL RING SETS



## 1/16", 1/16", 3/16" Plasma-Moly Carbon Steel Standard Tension Engine Sets

Part Number	Bore	Top Ring	Radial	Second Ring	Radial	Oil Ring	Radial
315-0036	4.000"	301-1012	.190"	302-0108	.170"	303-0115	.201"
315-0036.005	4.005"	301-1013	.190"	302-0109	.170"	303-0115	.201"
315-0036.025	4.025"	301-1015	.190"	302-0111	.170"	303-0117	.201"
315-0036.030	4.030"	301-1016	.190"	302-0112	.170"	303-0118	.201"
315-0036.035	4.035"	301-1017	.190"	302-0113	.170"	303-0118	.201"
315-0036.040	4.040"	301-1018	.190"	302-0115	.170"	303-0119	.201"
315-0036.045	4.045"	301-1019	.190"	302-0115	.170"	303-0119	.201"
315-0036.060	4.060"	301-1020	.190"	302-0116	.170"	303-0121	.201"
315-0036.065	4.065"	301-1021	.190"	302-0117	.170"	303-0121	.201"
315-0036.075	4.075"	301-1217	.190"	302-0119	.170"	303-0122	.201"
315-0036.085	4.085"	301-1218	.190"	302-0121	.170"	303-0123	.201"
315-0032	4.125"	301-1102	.190"	302-0127	.170"	303-0128	.201"
315-0032.005	4.130"	301-1103	.190"	302-0128	.170"	303-0128	.201"
315-0032.015	4.140"	301-1214	.190"	302-0292	.170"	303-0129	.201"
315-0032.025	4.150"	301-1104	.190"	302-0130	.170"	303-0130	.201"
315-0032.030	4.155"	301-1105	.190"	302-0131	.170"	303-0131	.201"
315-0032.035	4.160"	301-1106	.190"	302-0132	.170"	303-0131	.201"
315-0032.040	4.165"	300-0111	.193"	302-0133	.170"	303-0132	.201"
315-0032.045	4.170"	301-1107	.190"	302-0134	.170"	303-0132	.201"
315-0035	4.250"	301-1108	.190"	302-0139	.170"	303-0134	.201"
315-0035.005	4.255"	301-1109	.190"	302-0140	.170"	303-0134	.201"
315-0035.030	4.280"	301-1110	.190"	302-0141	.170"	303-0136	.201"
315-0035.035	4.285"	301-1111	.190"	302-0142	.170"	303-0136	.201"
315-0035.060	4.310"	301-1112	.190"	302-0145	.170"	303-0138	.201"
315-0035.065	4.315"	301-1113	.190"	302-0146	.170"	303-0138	.201"
315-0029.005	4.325"	300-0181	.201"	302-1067	.170"	303-0258	.201"
315-0029.035	4.355"	301-1114	.190"	302-1069	.170"	303-0261	.201"
315-0029.060	4.380"	300-0180	.204"	302-1073	.170"	303-0141	.201"
315-0029.065	4.385"	301-1116	.190"	302-1073	.170"	303-0141	.201"
315-0025.035	4.395"	301-1117	.190"	302-1075	.170"	303-0142	.201"
315-0057.005	4.445"	301-1118	.190"	302-0316	.170"	303-0642	.201"
315-0053.005	4.505"	301-1120	.190"	302-0319	.170"	303-0359	.201"
315-0053.035	4.535"	301-1121	.190"	302-0320	.170"	303-0360	.201"
315-0053.065	4.565"	301-1123	.190"	302-0321	.170"	303-0361	.201"
315-0106.005	4.567"	301-1124	.190"	302-0902	.212"	303-0361	.201"
315-0056.005	4.605"	301-1125	.190"	302-0323	.170"	303-0362	.170"
315-0056.025	4.630"	301-1127	.190"	302-0324	.170"	303-0644	.170"

● New Number

★ Discontinued

**5/64", 5/64", 3/16" Plasma-Moly Carbon Steel Low Tension Engine Sets**

Part Number	Bore	Top Ring	Radial	Second Ring	Radial	Oil Ring	Radial
315-0051	4.000"	301-0142	.187"	302-0265	.187"	303-0155	.201"
315-0051.030	4.030"	301-0969	.147"	302-0271	.187"	303-0158	.201"
315-0051.060	4.060"	301-0971	.147"	302-0274	.187"	303-0161	.201"

**5/64", 5/64", 3/16" Plasma-Moly Carbon Steel Standard Tension Engine Sets**

Part Number	Bore	Top Ring	Radial	Second Ring	Radial	Oil Ring	Radial
315-0034	4.000"	301-0142	.187"	302-0265	.187"	303-0115	.201"
315-0034.030	4.030"	301-0969	.147"	302-0271	.187"	303-0118	.201"
315-0034.035	4.035"	300-0565	.187"	302-0271	.187"	303-0118	.201"
315-0034.040	4.040"	301-0970	.147"	302-0272	.187"	303-0119	.201"
315-0034.045	4.045"	300-0230	.187"	302-0272	.187"	303-0119	.201"
315-0034.060	4.060"	301-0971	.147"	302-0274	.187"	303-0121	.201"

MAHLE Performance plasma-moly ductile ring sets are designed for the serious racer. These sets feature rings that maximize combustion sealing and minimize frictional losses to increase horsepower and oil control. These sets include reduced radial wall (RRW) top rings, and CP-20™ oil rings to reduce tension, improve conformability and maximize power output. Ring sets with low and ultra low tension oil rings are not recommended for street use and should utilize a vacuum pump for maximum performance.

### **.043", 1/16", 3/16" Plasma-Moly Ductile Iron Low Tension Engine Sets**

Part Number	Bore	Top Ring	Radial	Second Ring	Radial	Oil Ring	Radial
315-0113.065★	4.315"	300-0356	.198"	302-0146	.170"	303-0179	.201"
315-0054.005★	4.505"	300-0367	.210"	302-0319	.170"	303-0204	.201"

### **.043", 1/16", 3/16" Plasma-Moly Ductile Iron Low Tension Reduced Radial Wall Engine Sets**

Part Number	Bore	Top Ring	Radial	Second Ring	Radial	Oil Ring	Radial
315-0123.035★	4.285"	300-0383	.160"	302-0142	.170"	303-0177	.201"
315-0123.065★	4.315"	300-0384	.160"	302-0146	.170"	303-0179	.201"

### **.043", 1/16", 3/16" Plasma-Moly Ductile Iron Standard Tension Reduced Radial Wall Engine Sets**

Part Number	Bore	Top Ring	Radial	Second Ring	Radial	Oil Ring	Radial
315-0122.045	4.160"	301-1193	.157"	302-0132	.170"	303-0131	.201"
315-0124.035★	4.285"	300-0383	.160"	302-0142	.170"	303-0136	.201"
315-0124.065	4.315"	300-0384	.160"	302-0146	.170"	303-0138	.201"

### **1/16", 1/16", 3/16" Plasma-Moly Ductile Iron Low Tension Engine Sets**

Part Number	Bore	Top Ring	Radial	Second Ring	Radial	Oil Ring	Radial
315-0105.005	4.567"	301-1124	.190"	302-0902	.212"	303-0663	.201"

### **1/16", 1/16", 3/16" Plasma-Moly Ductile Iron Standard Tension Engine Sets**

Part Number	Bore	Top Ring	Radial	Second Ring	Radial	Oil Ring	Radial
315-0106.045★	4.607"	300-0612	.212"	302-0323	.170"	303-0362	.170"

### **5/64", 5/64", 3/16" Plasma-Moly Ductile Iron Standard Tension Engine Sets**

Part Number	Bore	Top Ring	Radial	Second Ring	Radial	Oil Ring	Radial
315-0028	4.250"	300-0214	.198"	302-0257	.198"	303-0134	.201"
315-0028.030	4.280"	300-0216	.198"	302-0259	.198"	303-0136	.201"
315-0028.060	4.310"	300-0218	.198"	302-0261	.198"	303-0138	.201"
315-0019.035	4.355"	300-0190	.201"	302-1161	.201"	303-0261	.201"

● New Number

★ Discontinued

MAHLE Performance 1.0MM upper compression rings utilize a proprietary HV385 thermal spray face coating developed specifically for extreme operating conditions combined with MAHLE's SAE 9254 steel base material providing a compression ring with unequaled strength and fatigue resistance which extends overall life and reduces breakage. MAHLE Performance 1.2MM SAE 9254 steel base material Napier lower compression rings provide unequaled durability levels demanded by today's high performance applications. MAHLE Performance 2.8MM CP-20™ performance oil control rings are designed to provide superior oil control in all performance applications. MAHLE Performance oil rings utilize bore specific designs and an exclusive 20 degree ear angle for the best possible side seal in the piston ring groove.

## 1.0MM, 1.2MM, 2.8MM HV385 Carbon Steel Standard Tension Reduced Radial Wall Engine Sets

Part Number	Bore	Top Ring	Radial	Second Ring	Radial	Oil Ring	Radial
315-0208	81.0MM / 3.189"	301-1220	.128"	302-1317	.135"	303-0908	.139"
315-0209	81.5MM / 3.209"	301-1222	.128"	302-1319	.135"	303-0910	.139"
315-0210	82.0MM / 3.228"	301-1223	.128"	302-1320	.135"	303-0911	.139"
315-0211	82.5MM / 3.248"	301-1225	.128"	302-1322	.135"	303-0912	.139"
315-0212	84.0MM / 3.307"	301-1226	.128"	302-1323	.135"	303-0915	.139"
315-0213	84.5MM / 3.327"	301-1228	.128"	302-1325	.135"	303-0916	.139"
315-0214	85.0MM / 3.346"	301-1229	.128"	302-1326	.135"	303-0917	.139"
315-0215	86.0MM / 3.386"	301-1232	.128"	302-1329	.135"	303-0919	.139"
315-0216	86.5MM / 3.406"	301-1233	.128"	302-1330	.135"	303-0920	.139"
315-0217	87.0MM / 3.425"	301-1234	.128"	302-1331	.135"	303-0921	.139"
315-0218	87.5MM / 3.445"	301-1236	.128"	302-1333	.135"	303-0923	.139"
315-0219	88.0MM / 3.465"	301-1237	.128"	302-1334	.135"	303-0924	.139"
315-0220	88.5MM / 3.484"	301-1238	.128"	302-1335	.135"	303-0925	.139"
315-0221	89.0MM / 3.504"	301-1239	.128"	302-1336	.135"	303-0926	.139"
315-0222	89.5MM / 3.524"	301-1240	.128"	302-1337	.135"	303-0927	.139"
315-0223	90.0MM / 3.543"	301-1241	.128"	302-1338	.135"	303-0932	.139"



● New Number

★ Discontinued

PISTON RING POSITION		
Top Ring	<b>UCR</b> (Upper Compression Ring)	
Second Ring	<b>LCR</b> (Lower Compression Ring)	
Oil Ring	<b>OCR</b> (Oil Control Ring)	
PISTON RING TYPES	1 TYPE CODE	DESCRIPTION
Radius Faced	<b>RF</b>	Barrel Faced, Upper Compression Ring
Beveled Radius Faced	<b>BR</b>	Positive Twist, Barrel Faced, Upper Compression Ring
Pressure Backed	<b>PB</b>	L-Shaped, Dykes Cut, Gas Pressure Backed Upper Compression Ring
Beveled Taper Face	<b>BT</b>	Positive Twist, Taper Faced, Upper Compression or Lower Compression Ring
Reverse Beveled Taper Face	<b>RBT</b>	Reverse or Negative Twist, Taper Faced, Lower Compression Ring Only
Napier/ Tapered Hook Groove	<b>THG</b>	Tapered Face, Hook Shaped Undercut, Lower Compression Ring Only
Napier/ Tapered Hook Micro	<b>THM</b>	Tapered Face, Reduced Hook Shaped Undercut, Lower Compression Ring Only
3 Piece Oil Ring	<b>CP20</b>	Chem-Polished Stainless Steel Expander, Chrome Plated Carbon Steel Rails
1 Piece Oil Ring	<b>U-Flex</b>	U-Shaped, Segmented Carbon Steel, Oil Control Ring
PISTON RING BASE MATERIALS	2 MATERIAL CODE	DESCRIPTION
Cast Iron	<b>10</b>	Grey Cast Iron
Ductile Iron	<b>18</b>	High Strength Nodular Cast Iron
PC479	<b>19</b>	Hardened High Strength Nodular Cast Iron
Stainless Steel	<b>12</b>	Gas Nitrided Stainless Steel
SAE 9254	<b>13</b>	9254 Carbon Steel
PISTON RING FACE COATINGS	3 FACING CODE	DESCRIPTION
Chrome	<b>U</b>	Chrome Plated Face Coating
GNS	<b>NG</b>	Gas Nitrided Surface Hardening Treatment
PVD	<b>PVD</b>	Physical Vapor Deposition Surface Treatment
PF251	<b>PF</b>	Traditional Plasma Thermal Spray Coating
PF278	<b>PF</b>	Carbide Fortified Plasma Thermal Spray Coating
HV385	<b>PF</b>	385 HVOF High Density Thermal Spray Coating

**Example:** **RF** - **13** **PF**

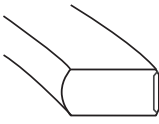
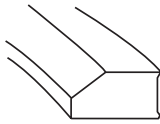
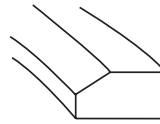
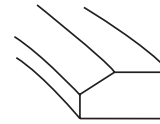
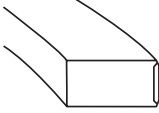
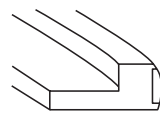
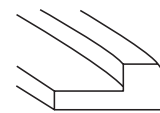
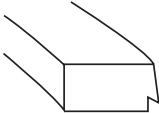
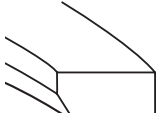
- 1 Ring Type Code: **RF** = Barrel Faced, Upper Compression Ring
- 2 Material Code: **13** = 9254 Carbon Steel
- 3 Face Coating or Treatment: **PF** = Thermal Spray Coating (Can be Traditional or Fortified Plasma, or High Density HV385)

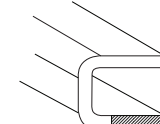
<p><b>RF-13PF</b> Radius Back Steel</p>	<p><b>BR-18PF / BR-13PF</b> Twisted Barrel Faced</p>	<p><b>BR-12NG</b> Positive Twist Gas Nitrided Stainless Steel</p>	<p><b>BR-19</b> Barrel Faced Positive Twist Hardened Ductile Iron</p>
			
<p><b>RF-13U</b> Non-Twisted Barrel Faced</p>	<p><b>PB-18PF</b> Dykes</p>	<p><b>PB-18 / PB-19</b> Dykes</p>	
			
<p><b>THM-13 / THM-10 / THG-10</b> Taper Hook Groove (Napier)</p>	<p><b>RBT-10</b> Reverse-Twist Taper Faced</p>	<p><b>CP-20™</b></p>	<p><b>U-Flex</b></p>
			

# OPEN STOCK RINGS



Bore	Axial Height	Radial Wall	Base Material	Face Coating	Ring Type (Tension)	Position	Part Number
2.952"	1.5MM	.130"	Grey Iron		BT-10	LCR	302-0553★
3.186"	5/64"	.133"	Grey Iron		RBT-10	LCR	302-0219★
3.189"	1.0MM	.128"	9254 Steel	HV385	RF-13PF	UCR	301-1220
3.189"	1.2MM	.123"	9254 Steel	Chrome	RF-13U	UCR	301-0384
3.189"	1.2MM	.135"	9254 Steel		THM-13	LCR	302-1317
3.189"	1.5MM	.131"	9254 Steel	Chrome	RF-13U	UCR	301-0582
3.189"	2.8MM	.139"	Stainless Steel	Chrome	CP-20 (Standard)	OCR	303-0908
3.189"	3.0MM	.121"	Stainless Steel	Chrome	CP-20 (Standard)	OCR	303-0498★
3.190"	4.0MM	.167"	Stainless Steel	Chrome	CP-20 (Standard)	OCR	303-0732★
3.195"	1.5MM	.130"	Ductile Iron	Chrome	RF-18U	UCR	300-0489★
3.198"	1.0MM	.128"	9254 Steel	HV385	RF-13PF	UCR	301-1221
3.198"	1.2MM	.135"	9254 Steel		THM-13	LCR	302-1318
3.198"	2.8MM	.139"	Stainless Steel	Chrome	CP-20 (Standard)	OCR	303-0909
3.209"	1.0MM	.128"	9254 Steel	HV385	RF-13PF	UCR	301-1222
3.209"	1.2MM	.135"	9254 Steel		THM-13	LCR	302-1319
3.209"	2.8MM	.139"	Stainless Steel	Chrome	CP-20 (Standard)	OCR	303-0910
3.209"	3.0MM	.121"	Stainless Steel	Chrome	CP-20 (Standard)	OCR	303-0499★
3.228"	1.0MM	.128"	9254 Steel	HV385	RF-13PF	UCR	301-1223
3.228"	1.2MM	.135"	9254 Steel		THM-13	LCR	302-1320
3.228"	2.8MM	.139"	Stainless Steel	Chrome	CP-20 (Standard)	OCR	303-0911
3.238"	1.0MM	.128"	9254 Steel	HV385	RF-13PF	UCR	301-1224
3.238"	1.2MM	.135"	9254 Steel		THM-13	LCR	302-1321
3.248"	1.0MM	.128"	9254 Steel	HV385	RF-13PF	UCR	301-1225
3.248"	1.2MM	.135"	9254 Steel		THM-13	LCR	302-1322
3.248"	2.8MM	.139"	Stainless Steel	Chrome	CP-20 (Standard)	OCR	303-0912
3.267"	2.8MM	.139"	Stainless Steel	Chrome	CP-20 (Standard)	OCR	303-0913
3.267"	3.0MM	.142"	Stainless Steel	Chrome	CP-20 (Standard)	OCR	303-0504
3.268"	1.5MM	.123"	9254 Steel	Chrome	RF-13U	UCR	301-0601
3.287"	2.8MM	.139"	Stainless Steel	Chrome	CP-20 (Standard)	OCR	303-0914
3.307"	1.0MM	.128"	9254 Steel	HV385	RF-13PF	UCR	301-1226
3.307"	1.2MM	.131"	9254 Steel	Chrome	RF-13U	UCR	301-0396★
3.307"	1.2MM	.135"	9254 Steel		THM-13	LCR	302-1323
3.307"	2.8MM	.139"	Stainless Steel	Chrome	CP-20 (Standard)	OCR	303-0915

Note: For bulk open stock rings, add a B suffix. ● New Number ★ Discontinued

Bore	Axial Height	Radial Wall	Base Material	Face Coating	Ring Type (Tension)	Position	Part Number
3.316"	1.0MM	.128"	9254 Steel	HV385	RF-13PF	UCR	301-1227
3.316"	1.2MM	.135"	9254 Steel		THM-13	LCR	302-1324
3.327"	1.0MM	.128"	9254 Steel	HV385	RF-13PF	UCR	301-1228
3.327"	1.2MM	.131"	9254 Steel	Chrome	RF-13U	UCR	301-0398★
3.327"	1.2MM	.135"	9254 Steel		THM-13	LCR	302-1325
3.327"	2.8MM	.139"	Stainless Steel	Chrome	CP-20 (Standard)	OCR	303-0916
3.336"	1.2MM	.131"	9254 Steel	Chrome	RF-13U	UCR	301-0400
3.338"	1.5MM	.136"	9254 Steel		THM-13	LCR	302-1391●
3.338"	3.0MM	.146"	Stainless Steel	Chrome	CP-20 (Standard)	OCR	303-0983●
3.346"	1.0MM	.128"	9254 Steel	HV385	RF-13PF	UCR	301-1229
3.346"	1.2MM	.131"	9254 Steel	Chrome	RF-13U	UCR	301-0401
3.346"	1.2MM	.135"	9254 Steel		THM-13	LCR	302-1326
3.346"	1.5MM	.131"	9254 Steel	Chrome	RF-13U	UCR	301-0611★
3.346"	1.5MM	.136"	9254 Steel		THM-13	LCR	302-1470●
3.346"	2.8MM	.139"	Stainless Steel	Chrome	CP-20 (Standard)	OCR	303-0917
3.356"	1.0MM	.128"	9254 Steel	HV385	RF-13PF	UCR	301-1230
3.356"	1.2MM	.135"	9254 Steel		THM-13	LCR	302-1327
3.366"	1.0MM	.128"	9254 Steel	HV385	RF-13PF	UCR	301-1231
3.366"	1.2MM	.136"	Grey Iron		BT-10	LCR	302-0481★
3.366"	1.2MM	.135"	9254 Steel		THM-13	LCR	302-1328
3.366"	1.5MM	.133"	Ductile Iron	Chrome	RF-18U	UCR	300-0506★
3.366"	1.5MM	.139"	9254 Steel	Chrome	RF-13U	UCR	301-0619★
3.366"	2.8MM	.139"	Stainless Steel	Chrome	CP-20 (Standard)	OCR	303-0918
3.368"	1.5MM	.127"	9254 Steel	PM278	RF-13PF	UCR	301-0935
3.376"	5/64"	.146"	9254 Steel	Chrome	RF-13U	UCR	301-0910★
3.385"	1.2MM	.131"	9254 Steel	Chrome	RF-13U	UCR	301-0409
3.385"	1.5MM	.136"	9254 Steel	PM278	RF-13PF	UCR	301-0449
3.385"	3.0MM	.140"	Stainless Steel	Chrome	CP-20 (Standard)	OCR	303-0938
3.386"	1.0MM	.128"	9254 Steel	HV385	RF-13PF	UCR	301-1232
3.386"	1.2MM	.135"	9254 Steel		THM-13	LCR	302-1329
3.386"	2.8MM	.139"	Stainless Steel	Chrome	CP-20 (Standard)	OCR	303-0919
3.405"	1.2MM	.131"	9254 Steel	Chrome	RF-13U	UCR	301-0410

● New Number

★ Discontinued

Note: For bulk open stock rings, add a B suffix.

# OPEN STOCK RINGS



Bore	Axial Height	Radial Wall	Base Material	Face Coating	Ring Type (Tension)	Position	Part Number
3.406"	1.0MM	.128"	9254 Steel	HV385	RF-13PF	UCR	301-1233
3.406"	1.2MM	.135"	9254 Steel		THM-13	LCR	302-1330
3.406"	2.8MM	.139"	Stainless Steel	Chrome	CP-20 (Standard)	OCR	303-0920
3.406"	3.0MM	.146"	Stainless Steel	Chrome	CP-20 (Standard)	OCR	303-0510
3.425"	1.0MM	.128"	9254 Steel	HV385	RF-13PF	UCR	301-1234
3.425"	1.2MM	.131"	9254 Steel	Chrome	RF-13U	UCR	301-0412
3.425"	1.2MM	.135"	9254 Steel		THM-13	LCR	302-1331
3.425"	1.5MM	.131"	9254 Steel	Chrome	RF-13U	UCR	301-0642
3.425"	1.5MM	.150"	Grey Iron		BT-10	LCR	302-0713
3.425"	2.8MM	.139"	Stainless Steel	Chrome	CP-20 (Standard)	OCR	303-0921
3.425"	3.0MM	.146"	Stainless Steel	Chrome	CP-20 (Standard)	OCR	303-0512
3.426"	4.0MM	.141"	Stainless Steel	Chrome	CP-20 (Standard)	OCR	303-0557
3.435"	1.0MM	.128"	9254 Steel	HV385	RF-13PF	UCR	301-1235
3.435"	1.2MM	.135"	9254 Steel		THM-13	LCR	302-1332
3.435"	2.8MM	.139"	Stainless Steel	Chrome	CP-20 (Standard)	OCR	303-0922
3.444"	1.5MM	.136"	9254 Steel	PM278	RF-13PF	UCR	301-0936
3.444"	3.0MM	.146"	Stainless Steel	Chrome	CP-20 (Standard)	OCR	303-0513
3.445"	1.0MM	.128"	9254 Steel	HV385	RF-13PF	UCR	301-1236
3.445"	1.2MM	.131"	9254 Steel	Chrome	RF-13U	UCR	301-0418
3.445"	1.2MM	.135"	9254 Steel		THM-13	LCR	302-1333
3.445"	1.5MM	.150"	Grey Iron		BT-10	LCR	302-0717
3.445"	2.8MM	.139"	Stainless Steel	Chrome	CP-20 (Standard)	OCR	303-0923
3.452"	1.5MM	.150"	9254 Steel		THM-13	LCR	302-1314
3.464"	1.2MM	.143"	9254 Steel	PM278	RF-13PF	UCR	301-0311
3.464"	1.2MM	.131"	9254 Steel	Chrome	RF-13U	UCR	301-0419
3.464"	1.5MM	.136"	9254 Steel	PM278	RF-13PF	UCR	301-0454
3.464"	1.5MM	.150"	Grey Iron		BT-10	LCR	302-1173●
3.464"	2.0MM	.114"	Stainless Steel	Chrome	CP-20 (Ultra Low)	OCR	303-0748
3.464"	2.0MM	.110"	Stainless Steel	GNS	CP-20 (Standard)	OCR	303-0982●
3.464"	3.0MM	.146"	Stainless Steel	Chrome	CP-20 (Standard)	OCR	303-0758
3.465"	1.0MM	.128"	9254 Steel	HV385	RF-13PF	UCR	301-1237
3.465"	1.2MM	.135"	9254 Steel		THM-13	LCR	302-1334
3.465"	2.8MM	.139"	Stainless Steel	Chrome	CP-20 (Standard)	OCR	303-0924
3.465"	4.0MM	.159"	Stainless Steel	Chrome	CP-20 (Standard)	OCR	303-0560

Note: For bulk open stock rings, add a B suffix.

● New Number

★ Discontinued

Bore	Axial Height	Radial Wall	Base Material	Face Coating	Ring Type (Tension)	Position	Part Number
3.484"	1.0MM	.128"	9254 Steel	HV385	RF-13PF	UCR	301-1238
3.484"	1.2MM	.135"	9254 Steel		THM-13	LCR	302-1335
3.484"	2.8MM	.139"	Stainless Steel	Chrome	CP-20 (Standard)	OCR	303-0925
3.484"	3.0MM	.141"	Stainless Steel	Chrome	CP-20 (Standard)	OCR	303-0760
3.484"	3.0MM	.138"	Stainless Steel	Chrome	CP-20 (Standard)	OCR	303-0985●
3.504"	1.0MM	.128"	9254 Steel	HV385	RF-13PF	UCR	301-1239
3.504"	1.2MM	.135"	9254 Steel		THM-13	LCR	302-1336
3.504"	1.5MM	.131"	9254 Steel	Chrome	RF-13U	UCR	301-0660
3.504"	2.8MM	.139"	Stainless Steel	Chrome	CP-20 (Standard)	OCR	303-0926
3.504"	4.75MM	.201"	Stainless Steel	Chrome	CP-20 (Standard)	OCR	303-0594
3.515"	1.5MM	.139"	9254 Steel	Chrome	RF-13U	UCR	301-0664
3.523"	1.5MM	.131"	9254 Steel	Chrome	RF-13U	UCR	301-0661
3.523"	4.0MM	.139"	Stainless Steel	Chrome	CP-20 (Standard)	OCR	303-0731
3.524"	1.0MM	.128"	9254 Steel	HV385	RF-13PF	UCR	301-1240
3.524"	1.2MM	.135"	9254 Steel		THM-13	LCR	302-1337
3.524"	2.8MM	.139"	Stainless Steel	Chrome	CP-20 (Standard)	OCR	303-0927
3.533"	1.5MM	.143"	9254 Steel	PM278	RF-13PF	UCR	301-0460
3.533"	1.5MM	.131"	9254 Steel	Chrome	RF-13U	UCR	301-0662
3.543"	1.0MM	.128"	9254 Steel	HV385	RF-13PF	UCR	301-1241
3.543"	1.2MM	.135"	9254 Steel		THM-13	LCR	302-1338
3.543"	1.5MM	.131"	9254 Steel	Chrome	RF-13U	UCR	301-0663
3.543"	2.8MM	.139"	Stainless Steel	Chrome	CP-20 (Standard)	OCR	303-0932
3.551"	1.5MM	.143"	9254 Steel	PM278	RF-13PF	UCR	301-0469
3.551"	1.5MM	.150"	9254 Steel		THM-13	LCR	302-1268
3.551"	3.0MM	.151"	Stainless Steel	Chrome	CP-20 (Standard)	OCR	303-0514
3.553"	1.0MM	.128"	9254 Steel	HV385	RF-13PF	UCR	301-1242
3.553"	1.2MM	.135"	9254 Steel		THM-13	LCR	302-1339
3.556"	1.0MM	.143"	9254 Steel	HV385	RF-13PF	UCR	301-1253
3.556"	1.0MM	.136"	9254 Steel		THM-13	LCR	302-1356
3.556"	1.5MM	.166"	Grey Iron		RBT-10	LCR	302-0209
3.556"	2.0MM	.113"	Stainless Steel	Chrome	CP-20 (Standard)	OCR	303-0951
3.561"	1.5MM	.151"	9254 Steel		THM-13	LCR	302-1404●
3.561"	3.0MM	.150"	Stainless Steel	Chrome	CP-20 (Low)	OCR	303-0763

● New Number

★ Discontinued

Note: For bulk open stock rings, add a B suffix.

# OPEN STOCK RINGS



Bore	Axial Height	Radial Wall	Base Material	Face Coating	Ring Type (Tension)	Position	Part Number
3.563"	1.0MM	.128"	9254 Steel	HV385	RF-13PF	UCR	301-1243
3.563"	1.2MM	.135"	9254 Steel		THM-13	LCR	302-1340
3.563"	1.5MM	.143"	9254 Steel	PM278	RF-13PF	UCR	301-0462
3.564"	4.75MM	.201"	Stainless Steel	Chrome	CP-20 (Standard)	OCR	303-0598
3.570"	1.2MM	.142"	9254 Steel	PM278	RF-13PF	UCR	301-0321
3.570"	1.5MM	.143"	9254 Steel	PM278	RF-13PF	UCR	301-0470
3.570"	1.5MM	.155"	9254 Steel		THM-13	LCR	302-1155
3.570"	3.0MM	.151"	Stainless Steel	Chrome	CP-20 (Standard)	OCR	303-0515
3.576"	1.0MM	.143"	9254 Steel	HV385	RF-13PF	UCR	301-1254
3.576"	1.0MM	.136"	9254 Steel		THM-13	LCR	302-1357
3.576"	1.5MM	.155"	9254 Steel	PM278	RF-13PF	UCR	301-0108
3.576"	2.0MM	.113"	Stainless Steel	Chrome	CP-20 (Standard)	OCR	303-0952
3.586"	1.0MM	.143"	9254 Steel	HV385	RF-13PF	UCR	301-1255
3.586"	1.0MM	.136"	9254 Steel		THM-13	LCR	302-1358
3.586"	1.5MM	.139"	9254 Steel	Chrome	RF-13U	UCR	301-0678★
3.586"	2.0MM	.113"	Stainless Steel	Chrome	CP-20 (Standard)	OCR	303-0953
3.622"	1.2MM	.146"	9254 Steel	Chrome	RF-13U	UCR	301-0428
3.626"	1.5MM	.139"	9254 Steel	Chrome	RF-13U	UCR	301-0889★
3.629"	1.2MM	.143"	9254 Steel	Plasma-Moly	RF-13PF	UCR	301-1252●
3.634"	1.0MM	.143"	9254 Steel	HV385	RF-13PF	UCR	301-1256
3.634"	1.0MM	.136"	9254 Steel		THM-13	LCR	302-1359
3.634"	2.0MM	.113"	Stainless Steel	Chrome	CP-20 (Standard)	OCR	303-0954
3.644"	1.0MM	.143"	9254 Steel	HV385	RF-13PF	UCR	301-1257
3.644"	1.0MM	.136"	9254 Steel		THM-13	LCR	302-1360
3.644"	2.0MM	.113"	Stainless Steel	Chrome	CP-20 (Standard)	OCR	303-0955
3.645"	1.5MM	.139"	9254 Steel	Chrome	RF-13U	UCR	301-0685★
3.661"	1.5MM	.139"	9254 Steel	Chrome	RF-13U	UCR	301-0684
3.675"	1.5MM	.139"	9254 Steel	Chrome	RF-13U	UCR	301-0687★
3.700"	2.0MM	.115"	Stainless Steel	GNS	CP-20 (Standard)	OCR	303-0996●
3.759"	1.2MM	.133"	9254 Steel	HV385	RF-13PF	UCR	301-1205
3.759"	1.2MM	.135"	9254 Steel		THM-13	LCR	302-1297
3.759"	2.5MM	.129"	Stainless Steel	PVD	CP-20 (Standard)	OCR	303-0878

Note: For bulk open stock rings, add a B suffix. ● New Number ★ Discontinued

Bore	Axial Height	Radial Wall	Base Material	Face Coating	Ring Type (Tension)	Position	Part Number
3.771"	1.0MM	.143"	9254 Steel	HV385	RF-13PF	UCR	301-1258
3.771"	1.0MM	.136"	9254 Steel		THM-13	LCR	302-1361
3.771"	2.0MM	.113"	Stainless Steel	Chrome	CP-20 (Standard)	OCR	303-0956
3.779"	1.2MM	.133"	9254 Steel	HV385	RF-13PF	UCR	301-1206
3.779"	1.2MM	.135"	9254 Steel		THM-13	LCR	302-1298
3.779"	1.5MM	.138"	9254 Steel	Chrome	RF-13U	UCR	301-0692★
3.779"	1.5MM	.152"	9254 Steel	PM278	RF-13PF	UCR	301-0937
3.779"	2.5MM	.129"	Stainless Steel	PVD	CP-20 (Standard)	OCR	303-0879
3.779"	3.0MM	.145"	Stainless Steel	Chrome	CP-20 (Low)	OCR	303-0735
3.781"	1.0MM	.143"	9254 Steel	HV385	RF-13PF	UCR	301-1259
3.781"	1.0MM	.136"	9254 Steel		THM-13	LCR	302-1362
3.781"	2.0MM	.113"	Stainless Steel	Chrome	CP-20 (Standard)	OCR	303-0957
3.785"	5/64"	.175"	Ductile Iron	PM251	BR-18PF	UCR	300-0552★
3.790"	3/16"	.201"	Stainless Steel	Chrome	CP-20 (Standard)	OCR	303-0625
3.791"	1.0MM	.143"	9254 Steel	HV385	RF-13PF	UCR	301-1260
3.791"	1.0MM	.136"	9254 Steel		THM-13	LCR	302-1363
3.791"	2.0MM	.113"	Stainless Steel	Chrome	CP-20 (Standard)	OCR	303-0958
3.800"	1.2MM	.151"	9254 Steel	PM278	RF-13PF	UCR	301-0334
3.801"	1.0MM	.143"	9254 Steel	HV385	RF-13PF	UCR	301-1261
3.801"	1.0MM	.136"	9254 Steel		THM-13	LCR	302-1364
3.801"	2.0MM	.113"	Stainless Steel	Chrome	CP-20 (Standard)	OCR	303-0959
3.805"	1.0MM	.143"	9254 Steel	HV385	RF-13PF	UCR	301-1262
3.805"	1.0MM	.136"	9254 Steel		THM-13	LCR	302-1365
3.805"	2.0MM	.113"	Stainless Steel	Chrome	CP-20 (Standard)	OCR	303-0960
3.810"	3.0MM	.154"	Stainless Steel	Chrome	CP-20 (Low)	OCR	303-0064
3.810"	3/16"	.201"	Stainless Steel	Chrome	CP-20 (Standard)	OCR	303-0628
3.811"	1.5MM	.151"	9254 Steel	PM278	RF-13PF	UCR	301-0486
3.815"	1.0MM	.143"	9254 Steel	HV385	RF-13PF	UCR	301-1263
3.815"	1.0MM	.136"	9254 Steel		THM-13	LCR	302-1366
3.815"	2.0MM	.113"	Stainless Steel	Chrome	CP-20 (Standard)	OCR	303-0961
3.825"	1.0MM	.143"	9254 Steel	HV385	RF-13PF	UCR	301-1264
3.825"	1.0MM	.136"	9254 Steel		THM-13	LCR	302-1367
3.825"	2.0MM	.113"	Stainless Steel	Chrome	CP-20 (Standard)	OCR	303-0962

● New Number

★ Discontinued

Note: For bulk open stock rings, add a B suffix.

# OPEN STOCK RINGS



Bore	Axial Height	Radial Wall	Base Material	Face Coating	Ring Type (Tension)	Position	Part Number
3.835"	1.0MM	.143"	9254 Steel	HV385	RF-13PF	UCR	301-1265
3.835"	1.0MM	.136"	9254 Steel		THM-13	LCR	302-1368
3.835"	2.0MM	.113"	Stainless Steel	Chrome	CP-20 (Standard)	OCR	303-0963
3.840"	4.75MM	.201"	Stainless Steel	Chrome	CP-20 (Standard)	OCR	303-0603
3.841"	1.5MM	.151"	9254 Steel	PM278	RF-13PF	UCR	301-0488
3.875"	1.2MM	.142"	Stainless Steel	GNS	BR-12NG	UCR	301-1396●
3.875"	1.2MM	.140"	9254 Steel		THM-13	LCR	302-1504●
3.875"	3.0MM	.154"	Stainless Steel	Chrome	CP-20 (Low)	OCR	303-0068
3.902"	1.0MM	.143"	9254 Steel	HV385	RF-13PF	UCR	301-1266
3.902"	1.0MM	.136"	9254 Steel		THM-13	LCR	302-1369
3.902"	1.5MM	.151"	9254 Steel	PM278	RF-13PF	UCR	301-0495
3.902"	2.0MM	.113"	Stainless Steel	Chrome	CP-20 (Standard)	OCR	303-0964
3.905"	1.5MM	.140"	Stainless Steel	GNS	BR-12NG	UCR	301-1299●
3.905"	1.5MM	.154"	9254 Steel		THM-13	LCR	302-1405●
3.905"	3.0MM	.118"	Stainless Steel	Chrome	CP-20 (Standard)	OCR	303-1012●
3.905"	3/16"	.201"	Stainless Steel	Chrome	CP-20 (Low)	OCR	303-0147
3.907"	1.5MM	.163"	Grey Iron		THG-10	LCR	302-1156
3.909"	1.0MM	.143"	9254 Steel	HV385	RF-13PF	UCR	301-1267
3.909"	1.0MM	.136"	9254 Steel		THM-13	LCR	302-1370
3.909"	2.0MM	.113"	Stainless Steel	Chrome	CP-20 (Standard)	OCR	303-0965
3.910"	1/16"	.181"	Ductile Iron	PM251	BR-18PF	UCR	300-0178★
3.910"	1/16"	.181"	Grey Iron		RBT-10	LCR	302-0228★
3.917"	1.2MM	.133"	9254 Steel	HV385	RF-13PF	UCR	301-1207
3.917"	1.2MM	.135"	9254 Steel		THM-13	LCR	302-1299
3.922"	1.0MM	.143"	9254 Steel	HV385	RF-13PF	UCR	301-1268
3.922"	1.0MM	.136"	9254 Steel		THM-13	LCR	302-1371
3.922"	2.0MM	.113"	Stainless Steel	Chrome	CP-20 (Standard)	OCR	303-0966
3.927"	1.2MM	.133"	9254 Steel	HV385	RF-13PF	UCR	301-1208
3.927"	1.2MM	.135"	9254 Steel		THM-13	LCR	302-1300
3.927"	2.5MM	.129"	Stainless Steel	PVD	CP-20 (Standard)	OCR	303-0881
3.932"	1.0MM	.143"	9254 Steel	HV385	RF-13PF	UCR	301-1269
3.932"	1.0MM	.136"	9254 Steel		THM-13	LCR	302-1372
3.932"	2.0MM	.113"	Stainless Steel	Chrome	CP-20 (Standard)	OCR	303-0967
3.935"	3.0MM	.151"	Stainless Steel	Chrome	CP-20 (Low)	OCR	303-0070

Note: For bulk open stock rings, add a B suffix. ● New Number ★ Discontinued

Bore	Axial Height	Radial Wall	Base Material	Face Coating	Ring Type (Tension)	Position	Part Number
3.937"	.043"	.151"	9254 Steel	PM278	BR-13PF	UCR	301-1010★
3.937"	1.2MM	.143"	9254 Steel	PM278	RF-13PF	UCR	301-0912★
3.937"	1.2MM	.133"	9254 Steel	HV385	RF-13PF	UCR	301-1209
3.937"	1.2MM	.135"	9254 Steel		THM-13	LCR	302-1301
3.937"	1.5MM	.151"	9254 Steel	PM251	RF-13PF	UCR	301-1011
3.937"	1.5MM	.150"	9254 Steel		THM-13	LCR	302-1269
3.937"	2.5MM	.129"	Stainless Steel	PVD	CP-20 (Standard)	OCR	303-0882
3.937"	3.0MM	.146"	Stainless Steel	Chrome	CP-20 (Standard)	OCR	303-0283
3.940"	3/16"	.201"	Stainless Steel	Chrome	CP-20 (Standard)	OCR	303-0112
3.942"	1.0MM	.143"	9254 Steel	HV385	RF-13PF	UCR	301-1270
3.942"	1.0MM	.136"	9254 Steel		THM-13	LCR	302-1373
3.942"	1.5MM	.151"	9254 Steel	PM278	RF-13PF	UCR	301-0115★
3.942"	1.5MM	.163"	Grey Iron		THG-10	LCR	302-0217
3.942"	2.0MM	.113"	Stainless Steel	Chrome	CP-20 (Standard)	OCR	303-0968
3.952"	1.0MM	.143"	9254 Steel	HV385	RF-13PF	UCR	301-1271
3.952"	1.0MM	.136"	9254 Steel		THM-13	LCR	302-1374
3.952"	2.0MM	.113"	Stainless Steel	Chrome	CP-20 (Standard)	OCR	303-0969

● New Number

★ Discontinued

Note: For bulk open stock rings, add a B suffix.

# OPEN STOCK RINGS



Bore	Axial Height	Radial Wall	Base Material	Face Coating	Ring Type (Tension)	Position	Part Number
4.000"	1.0MM	.143"	9254 Steel	HV385	RF-13PF	UCR	301-1052
4.000"	1.0MM	.136"	9254 Steel		THM-13	LCR	302-1210
4.000"	.043"	.157"	Stainless Steel	GNS	BR-12NG	UCR	301-1161
4.000"	1.2MM	.147"	9254 Steel	PM278	BR-13PF	UCR	301-0001
4.000"	1.2MM	.142"	Stainless Steel	GNS	BR-12NG	UCR	301-1421●
4.000"	1.2MM	.140"	9254 Steel		THM-13	LCR	302-1529●
4.000"	1.5MM	.172"	Ductile Iron	Chrome	BR-18U	UCR	300-0697★
4.000"	1.5MM	.155"	9254 Steel	PM278	RF-13PF	UCR	301-0506
4.000"	1.5MM	.150"	9254 Steel		THM-13	LCR	302-1204
4.000"	1.5MM	.154"	9254 Steel		THM-13	LCR	302-1424●
4.000"	1/16"	.190"	9254 Steel	PM278	BR-13PF	UCR	301-1012
4.000"	1/16"	.170"	Grey Iron		THG-10	LCR	302-0108
4.000"	5/64"	.147"	9254 Steel	PM251	RF-13PF	UCR	301-0966
4.000"	2.0MM	.113"	Stainless Steel	Chrome	CP-20 (Low)	OCR	303-0808
4.000"	2.0MM	.113"	Stainless Steel	Chrome	CP-20 (Standard)	OCR	303-0775
4.000"	2.5MM	.119"	Stainless Steel	Chrome	CP-20 (Low)	OCR	303-0463
4.000"	3.0MM	.151"	Stainless Steel	Chrome	CP-20 (Low)	OCR	303-0072
4.000"	3.0MM	.151"	Stainless Steel	Chrome	CP-20 (Standard)	OCR	303-0305
4.000"	3.0MM	.118"	Stainless Steel	Chrome	CP-20 (Standard)	OCR	303-1031●
4.000"	3/16"	.153"	Stainless Steel	Chrome	CP-20 (Low)	OCR	303-0633
4.000"	3/16"	.201"	Stainless Steel	Chrome	CP-20 (Low)	OCR	303-0155
4.000"	3/16"	.201"	Stainless Steel	Chrome	CP-20 (Standard)	OCR	303-0115
4.000"	4.0MM	.156"	Stainless Steel	Chrome	CP-20 (Standard)	OCR	303-0241
4.005"	1.0MM	.143"	9254 Steel	HV385	RF-13PF	UCR	301-1053
4.005"	.043"	.157"	Stainless Steel	GNS	BR-12NG	UCR	301-1162
4.005"	.043"	.140"	Grey Iron		THM-10	LCR	302-0327★
4.005"	.043"	.135"	9254 Steel		THM-13	LCR	302-1307
4.005"	1.2MM	.147"	9254 Steel	PM278	BR-13PF	UCR	301-0002
4.005"	1.5MM	.140"	Stainless Steel	GNS	BR-12NG	UCR	301-1319●
4.005"	1.5MM	.150"	9254 Steel		THM-13	LCR	302-1262
4.005"	1.5MM	.154"	9254 Steel		THM-13	LCR	302-1425●
4.005"	1/16"	.187"	PC479		BR-19	UCR	301-0206
4.005"	1/16"	.190"	9254 Steel	PM278	BR-13PF	UCR	301-1013
4.005"	1/16"	.170"	Grey Iron		THG-10	LCR	302-0109
4.005"	2.0MM	.113"	Stainless Steel	Chrome	CP-20 (Low)	OCR	303-0809
4.005"	2.0MM	.113"	Stainless Steel	Chrome	CP-20 (Standard)	OCR	303-0776
4.005"	2.5MM	.119"	Stainless Steel	Chrome	CP-20 (Low)	OCR	303-0464
4.005"	3.0MM	.118"	Stainless Steel	Chrome	CP-20 (Standard)	OCR	303-1032●

Note: For bulk open stock rings, add a B suffix.

● New Number

★ Discontinued

Bore	Axial Height	Radial Wall	Base Material	Face Coating	Ring Type (Tension)	Position	Part Number
4.010"	1.0MM	.143"	9254 Steel	HV385	RF-13PF	UCR	301-1054
4.010"	1.0MM	.136"	9254 Steel		THM-13	LCR	302-1211
4.010"	.043"	.157"	Stainless Steel	GNS	BR-12NG	UCR	301-1163
4.010"	.043"	.135"	9254 Steel		THM-13	LCR	302-1291
4.010"	1.2MM	.142"	Stainless Steel	GNS	BR-12NG	UCR	301-1423●
4.010"	1.2MM	.140"	9254 Steel		THM-13	LCR	302-1531●
4.010"	1.5MM	.151"	9254 Steel	HV385	RF-13PF	UCR	301-0973
4.010"	1.5MM	.140"	Stainless Steel	GNS	BR-12NG	UCR	301-1320●
4.010"	1.5MM	.154"	9254 Steel		THM-13	LCR	302-1426●
4.010"	2.0MM	.113"	Stainless Steel	Chrome	CP-20 (Low)	OCR	303-0810
4.010"	2.0MM	.113"	Stainless Steel	Chrome	CP-20 (Standard)	OCR	303-0777
4.010"	3.0MM	.118"	Stainless Steel	Chrome	CP-20 (Standard)	OCR	303-1033●
4.015"	1.0MM	.143"	9254 Steel	HV385	RF-13PF	UCR	301-1055
4.015"	.043"	.157"	Stainless Steel	GNS	BR-12NG	UCR	301-1164
4.015"	.043"	.135"	9254 Steel		THM-13	LCR	302-1295
4.015"	3.0MM	.169"	Ductile Iron	Chrome	RFK-18U Keystone	UCR	300-0705
4.015"	.0925"	.172"	Grey Iron		BT-10	LCR	302-1397●
4.015"	2.0MM	.113"	Stainless Steel	Chrome	CP-20 (Low)	OCR	303-0811
4.015"	2.0MM	.113"	Stainless Steel	Chrome	CP-20 (Standard)	OCR	303-0860
4.015"	4.0MM	.128"	Grey Iron	Chrome	MCL-40URW (Standard)	OCR	303-0997●
4.020"	1.0MM	.143"	9254 Steel	HV385	RF-13PF	UCR	301-1056
4.020"	1.0MM	.136"	9254 Steel		THM-13	LCR	302-1212
4.020"	.043"	.157"	Stainless Steel	GNS	BR-12NG	UCR	301-1165
4.020"	1.2MM	.142"	Stainless Steel	GNS	BR-12NG	UCR	301-1425●
4.020"	1.2MM	.140"	9254 Steel		THM-13	LCR	302-1533●
4.020"	1.5MM	.155"	9254 Steel	PM278	RF-13PF	UCR	301-0507
4.020"	1.5MM	.140"	Stainless Steel	GNS	BR-12NG	UCR	301-1322●
4.020"	1.5MM	.150"	9254 Steel		THM-13	LCR	302-1205
4.020"	1.5MM	.154"	9254 Steel		THM-13	LCR	302-1428●
4.020"	1/16"	.190"	9254 Steel	PM278	BR-13PF	UCR	301-1014
4.020"	1/16"	.190"	9254 Steel	HV385	RF-13PF	UCR	301-1288●
4.020"	5/64"	.147"	9254 Steel	PM278	RF-13PF	UCR	301-0968
4.020"	5/64"	.145"	9254 Steel		THM-13	LCR	302-1392●
4.020"	2.0MM	.113"	Stainless Steel	Chrome	CP-20 (Low)	OCR	303-0812
4.020"	2.0MM	.113"	Stainless Steel	Chrome	CP-20 (Standard)	OCR	303-0778
4.020"	3.0MM	.151"	Stainless Steel	Chrome	CP-20 (Low)	OCR	303-0074
4.020"	3.0MM	.151"	Stainless Steel	Chrome	CP-20 (Standard)	OCR	303-0307
4.020"	3.0MM	.138"	Stainless Steel	GNS	MCL-42NGRW (Standard)	OCR	303-0986●
4.020"	3.0MM	.118"	Stainless Steel	Chrome	CP-20 (Standard)	OCR	303-1035●
4.020"	3/16"	.201"	Stainless Steel	Chrome	CP-20 (Standard)	OCR	303-0117

● New Number

★ Discontinued

Note: For bulk open stock rings, add a B suffix.

# OPEN STOCK RINGS



Bore	Axial Height	Radial Wall	Base Material	Face Coating	Ring Type (Tension)	Position	Part Number
4.025"	1.0MM	.143"	9254 Steel	HV385	RF-13PF	UCR	301-1057
4.025"	.043"	.157"	Stainless Steel	GNS	BR-12NG	UCR	301-1166
4.025"	.043"	.135"	9254 Steel		THM-13	LCR	302-1308
4.025"	1.2MM	.147"	9254 Steel	PM278	BR-13PF	UCR	301-0004
4.025"	1.5MM	.151"	9254 Steel	HV385	RF-13PF	UCR	301-1244
4.025"	1.5MM	.150"	9254 Steel		THM-13	LCR	302-1263
4.025"	1/16"	.190"	9254 Steel	PM278	BR-13PF	UCR	301-1015
4.025"	1/16"	.170"	Grey Iron		THG-10	LCR	302-0111
4.025"	2.0MM	.113"	Stainless Steel	Chrome	CP-20 (Low)	OCR	303-0813
4.025"	2.0MM	.113"	Stainless Steel	Chrome	CP-20 (Standard)	OCR	303-0857
4.030"	1.0MM	.143"	9254 Steel	HV385	RF-13PF	UCR	301-1058
4.030"	1.0MM	.136"	9254 Steel		THM-13	LCR	302-1213
4.030"	.043"	.157"	Stainless Steel	GNS	BR-12NG	UCR	301-1167
4.030"	1.2MM	.142"	Stainless Steel	GNS	BR-12NG	UCR	301-1427●
4.030"	1.2MM	.140"	9254 Steel		THM-13	LCR	302-1535●
4.030"	1.5MM	.155"	9254 Steel	HV385	RF-13PF	UCR	301-0508
4.030"	1.5MM	.140"	Stainless Steel	GNS	BR-12NG	UCR	301-1324●
4.030"	1.5MM	.150"	9254 Steel		THM-13	LCR	302-1206
4.030"	1.5MM	.154"	9254 Steel		THM-13	LCR	302-1430●
4.030"	1/16"	.190"	9254 Steel	PM278	BR-13PF	UCR	301-1016
4.030"	1/16"	.190"	9254 Steel	HV385	RF-13PF	UCR	301-1289●
4.030"	1/16"	.170"	Grey Iron		THG-10	LCR	302-0112
4.030"	5/64"	.147"	9254 Steel	PM278	RF-13PF	UCR	302-0969
4.030"	2.0MM	.113"	Stainless Steel	Chrome	CP-20 (Low)	OCR	303-0814
4.030"	2.0MM	.113"	Stainless Steel	Chrome	CP-20 (Standard)	OCR	303-0779
4.030"	3.0MM	.151"	Stainless Steel	Chrome	CP-20 (Low)	OCR	303-0075
4.030"	3.0MM	.151"	Stainless Steel	Chrome	CP-20 (Standard)	OCR	303-0308
4.030"	3.0MM	.138"	Stainless Steel	GNS	MCL-42NGRW (Standard)	OCR	303-0987●
4.030"	3.0MM	.118"	Stainless Steel	Chrome	CP-20 (Standard)	OCR	303-1037●
4.030"	3/16"	.201"	Stainless Steel	Chrome	CP-20 (Low)	OCR	303-0158
4.030"	3/16"	.201"	Stainless Steel	Chrome	CP-20 (Standard)	OCR	303-0118

Note: For bulk open stock rings, add a B suffix.

● New Number

★ Discontinued

Bore	Axial Height	Radial Wall	Base Material	Face Coating	Ring Type (Tension)	Position	Part Number
4.035"	1.0MM	.143"	9254 Steel	HV385	RF-13PF	UCR	301-1059
4.035"	1.0MM	.136"	9254 Steel		THM-13	LCR	302-1238
4.035"	.043"	.187"	PC479		BR-19	UCR	301-0165★
4.035"	.043"	.157"	Stainless Steel	GNS	BR-12NG	UCR	301-1168
4.035"	.043"	.135"	9254 Steel		THM-13	LCR	302-1252
4.035"	1.2MM	.147"	9254 Steel	PM278	BR-13PF	UCR	301-0006
4.035"	1.5MM	.181"	Ductile Iron	PM251	BR-18PF	UCR	300-0658★
4.035"	1.5MM	.151"	9254 Steel	HV385	RF-13PF	UCR	301-1245
4.035"	1.5MM	.140"	Stainless Steel	GNS	BR-12NG	UCR	301-1325●
4.035"	1.5MM	.150"	9254 Steel		THM-13	LCR	302-1267
4.035"	1.5MM	.154"	9254 Steel		THM-13	LCR	302-1431●
4.035"	1/16"	.187"	PC479		BR-19	UCR	301-0208
4.035"	1/16"	.190"	9254 Steel	PM278	BR-13PF	UCR	301-1017
4.035"	1/16"	.190"	9254 Steel	HV385	RF-13PF	UCR	301-1290●
4.035"	1/16"	.170"	Grey Iron		THG-10	LCR	302-0113
4.035"	5/64"	.187"	Grey Iron	PM278	RF-10PF	UCR	302-0565
4.035"	5/64"	.145"	9254 Steel		THM-13	LCR	302-1393●
4.035"	.0925"	.172"	Grey Iron		BT-10	LCR	302-1398●
4.035"	3.0MM	.169"	Ductile Iron	Chrome	RFK-18U Keystone	UCR	300-0706
4.035"	2.0MM	.113"	Stainless Steel	Chrome	CP-20 (Low)	OCR	303-0815
4.035"	2.0MM	.113"	Stainless Steel	Chrome	CP-20 (Standard)	OCR	303-0858
4.035"	3.0MM	.151"	Stainless Steel	Chrome	CP-20 (Low)	OCR	303-0744
4.035"	3.0MM	.138"	Stainless Steel	GNS	MCL-42NGRW (Standard)	OCR	303-0988●
4.035"	3.0MM	.118"	Stainless Steel	Chrome	CP-20 (Standard)	OCR	303-1039●
4.035"	4.0MM	.128"	Grey Iron	Chrome	MCL-40URW (Standard)	OCR	303-0998●

● New Number

★ Discontinued

Note: For bulk open stock rings, add a B suffix.

# OPEN STOCK RINGS



Bore	Axial Height	Radial Wall	Base Material	Face Coating	Ring Type (Tension)	Position	Part Number
4.040"	1.0MM	.143"	9254 Steel	HV385	RF-13PF	UCR	301-1060
4.040"	1.0MM	.136"	9254 Steel		THM-13	LCR	302-1214
4.040"	.043"	.157"	Stainless Steel	GNS	BR-12NG	UCR	301-1169
4.040"	.043"	.135"	9254 Steel		THM-13	LCR	302-1292
4.040"	1.2MM	.142"	Stainless Steel	GNS	BR-12NG	UCR	301-1429●
4.040"	1.2MM	.140"	9254 Steel		THM-13	LCR	302-1537●
4.040"	1.5MM	.155"	9254 Steel	HV385	RF-13PF	UCR	301-0509
4.040"	1.5MM	.140"	Stainless Steel	GNS	BR-12NG	UCR	301-1326●
4.040"	1.5MM	.150"	9254 Steel		THM-13	LCR	302-1207
4.040"	1.5MM	.154"	9254 Steel		THM-13	LCR	302-1432●
4.040"	1/16"	.190"	9254 Steel	PM278	BR-13PF	UCR	301-1018
4.040"	5/64"	.147"	9254 Steel	PM278	RF-13PF	UCR	301-0970
4.040"	5/64"	.145"	9254 Steel		THM-13	LCR	302-1394●
4.040"	2.0MM	.113"	Stainless Steel	Chrome	CP-20 (Low)	OCR	303-0816
4.040"	2.0MM	.113"	Stainless Steel	Chrome	CP-20 (Standard)	OCR	303-0780
4.040"	3.0MM	.151"	Stainless Steel	Chrome	CP-20 (Low)	OCR	303-0076
4.040"	3.0MM	.151"	Stainless Steel	Chrome	CP-20 (Standard)	OCR	303-0309
4.040"	3.0MM	.138"	Stainless Steel	GNS	MCL-42NGRW (Standard)	OCR	303-0989●
4.040"	3.0MM	.118"	Stainless Steel	Chrome	CP-20 (Standard)	OCR	303-1040●
4.040"	3/16"	.201"	Stainless Steel	Chrome	CP-20 (Low)	OCR	303-0159
4.040"	3/16"	.201"	Stainless Steel	Chrome	CP-20 (Standard)	OCR	303-0119
4.045"	1.0MM	.143"	9254 Steel	HV385	RF-13PF	UCR	301-1061
4.045"	1.0MM	.136"	9254 Steel		THM-13	LCR	302-1239
4.045"	.043"	.157"	Stainless Steel	GNS	BR-12NG	UCR	301-1170
4.045"	.043"	.135"	9254 Steel		THM-13	LCR	302-1294
4.045"	1.2MM	.147"	9254 Steel	PM278	BR-13PF	UCR	301-0007
4.045"	1.5MM	.151"	9254 Steel	HV385	RF-13PF	UCR	301-1246
4.045"	1.5MM	.140"	Stainless Steel	GNS	BR-12NG	UCR	301-1327●
4.045"	1.5MM	.150"	9254 Steel		THM-13	LCR	302-1264
4.045"	1.5MM	.154"	9254 Steel		THM-13	LCR	302-1433●
4.045"	1/16"	.187"	PC479		BR-19	UCR	301-0209
4.045"	1/16"	.190"	9254 Steel	PM278	BR-13PF	UCR	301-1019
4.045"	1/16"	.170"	Grey Iron		THG-10	LCR	302-0115
4.045"	5/64"	.187"	Ductile Iron	PM278	BR-18PF	UCR	300-0230
4.045"	2.0MM	.113"	Stainless Steel	Chrome	CP-20 (Low)	OCR	303-0817
4.045"	2.0MM	.113"	Stainless Steel	Chrome	CP-20 (Standard)	OCR	303-0859
4.045"	3.0MM	.118"	Stainless Steel	Chrome	CP-20 (Standard)	OCR	303-1042●

Note: For bulk open stock rings, add a B suffix.

● New Number

★ Discontinued

Bore	Axial Height	Radial Wall	Base Material	Face Coating	Ring Type (Tension)	Position	Part Number
4.050"	1.0MM	.143"	9254 Steel	HV385	RF-13PF	UCR	301-1095
4.050"	1.0MM	.136"	9254 Steel		THM-13	LCR	302-1215
4.050"	.043"	.157"	Stainless Steel	GNS	BR-12NG	UCR	301-1171
4.050"	1.2MM	.142"	Stainless Steel	GNS	BR-12NG	UCR	301-1431●
4.050"	1.2MM	.140"	9254 Steel		THM-13	LCR	302-1539●
4.050"	2.0MM	.113"	Stainless Steel	Chrome	CP-20 (Low)	OCR	303-0818
4.050"	2.0MM	.113"	Stainless Steel	Chrome	CP-20 (Standard)	OCR	303-0781
4.050"	3.0MM	.151"	Stainless Steel	Chrome	CP-20 (Standard)	OCR	303-0077
4.050"	3/16"	.201"	Stainless Steel	Chrome	CP-20 (Low)	OCR	303-0160
4.050"	3/16"	.201"	Stainless Steel	Chrome	CP-20 (Standard)	OCR	303-0120
4.055"	1.0MM	.143"	9254 Steel	HV385	RF-13PF	UCR	301-1062
4.055"	1.0MM	.136"	9254 Steel		THM-13	LCR	302-1284
4.055"	.043"	.157"	Stainless Steel	GNS	BR-12NG	UCR	301-1172
4.055"	.043"	.135"	9254 Steel		THM-13	LCR	302-1247
4.055"	1.2MM	.147"	9254 Steel	PM278	BR-13PF	UCR	301-0009
4.055"	1.5MM	.151"	9254 Steel	HV385	RF-13PF	UCR	301-0974
4.055"	1/16"	.190"	9254 Steel	HV385	BR-13PF	UCR	301-1280●
4.055"	5/64"	.170"	Ductile Iron		BT-18	LCR	302-1388●
4.055"	5/64"	.178"	Grey Iron	Chrome	BT-10UF	LCR	302-1376●
4.055"	.0925"	.172"	Grey Iron		BT-10	LCR	302-1399●
4.055"	3.0MM	.169"	Ductile Iron	Chrome	RFK-18U Keystone	UCR	300-0707
4.055"	3.0MM	.158"	Stainless Steel	GNS	RFK-12NG Keystone	UCR	301-1282●
4.055"	2.0MM	.113"	Stainless Steel	Chrome	CP-20 (Low)	OCR	303-0819
4.055"	2.0MM	.113"	Stainless Steel	Chrome	CP-20 (Standard)	OCR	303-0782
4.055"	3.0MM	.138"	Stainless Steel	GNS	MCL-42NGRW (Standard)	OCR	303-0970●
4.055"	4.0MM	.128"	Grey Iron	Chrome	MCL-40URW (Standard)	OCR	303-0999●

● New Number

★ Discontinued

Note: For bulk open stock rings, add a B suffix.

# OPEN STOCK RINGS



Bore	Axial Height	Radial Wall	Base Material	Face Coating	Ring Type (Tension)	Position	Part Number
4.060"	1.0MM	.143"	9254 Steel	HV385	RF-13PF	UCR	301-1096
4.060"	1.0MM	.136"	9254 Steel		THM-13	LCR	302-1285
4.060"	.043"	.157"	Stainless Steel	GNS	BR-12NG	UCR	301-1173
4.060"	1.2MM	.142"	Stainless Steel	GNS	BR-12NG	UCR	301-1433●
4.060"	1.2MM	.140"	9254 Steel		THM-13	LCR	302-1541●
4.060"	1.5MM	.140"	Stainless Steel	GNS	BR-12NG	UCR	301-1330●
4.060"	1.5MM	.150"	9254 Steel		THM-13	LCR	302-1208
4.060"	1.5MM	.154"	9254 Steel		THM-13	LCR	302-1436●
4.060"	1/16"	.190"	9254 Steel	PM278	BR-13PF	UCR	301-1020
4.060"	1/16"	.170"	Grey Iron		THG-10	LCR	302-0116
4.060"	5/64"	.147"	9254 Steel	PM278	RF-13PF	UCR	302-0971
4.060"	2.0MM	.113"	Stainless Steel	Chrome	CP-20 (Low)	OCR	303-0820
4.060"	2.0MM	.113"	Stainless Steel	Chrome	CP-20 (Standard)	OCR	303-0783
4.060"	3.0MM	.151"	Stainless Steel	Chrome	CP-20 (Low)	OCR	303-0079
4.060"	3.0MM	.151"	Stainless Steel	Chrome	CP-20 (Standard)	OCR	303-0311
4.060"	3.0MM	.118"	Stainless Steel	Chrome	CP-20 (Standard)	OCR	303-1045●
4.060"	3/16"	.201"	Stainless Steel	Chrome	CP-20 (Low)	OCR	303-0161
4.060"	3/16"	.153"	Stainless Steel	Chrome	CP-20 (Low)	OCR	303-0638
4.060"	3/16"	.201"	Stainless Steel	Chrome	CP-20 (Standard)	OCR	303-0121
4.060"	4.0MM	.156"	Stainless Steel	Chrome	CP-20 (Standard)	OCR	303-0295
4.065"	1.0MM	.143"	9254 Steel	HV385	RF-13PF	UCR	301-1063
4.065"	1.0MM	.136"	9254 Steel		THM-13	LCR	302-1216
4.065"	.043"	.157"	Stainless Steel	GNS	BR-12NG	UCR	301-1174
4.065"	.043"	.135"	9254 Steel		THM-13	LCR	302-1293
4.065"	1.2MM	.147"	9254 Steel	PM278	BR-13PF	UCR	301-0010
4.065"	1.5MM	.151"	9254 Steel	HV385	RF-13PF	UCR	301-0975
4.065"	1.5MM	.140"	Stainless Steel	GNS	BR-12NG	UCR	301-1331●
4.065"	1.5MM	.150"	9254 Steel		THM-13	LCR	302-1209
4.065"	1.5MM	.154"	9254 Steel		THM-13	LCR	302-1437●
4.065"	1/16"	.187"	PC479		BR-19	UCR	301-0210
4.065"	1/16"	.190"	9254 Steel	PM278	BR-13PF	UCR	301-1021
4.065"	1/16"	.170"	Grey Iron		THG-10	LCR	302-0117
4.065"	5/64"	.178"	Grey Iron	Chrome	BT-10UF	LCR	302-1377●
4.065"	3.0MM	.158"	Stainless Steel	GNS	RFK-12NG Keystone	UCR	301-1283●
4.065"	2.0MM	.113"	Stainless Steel	Chrome	CP-20 (Low)	OCR	303-0821
4.065"	2.0MM	.113"	Stainless Steel	Chrome	CP-20 (Standard)	OCR	303-0784
4.065"	3.0MM	.138"	Stainless Steel	GNS	MCL-42NGRW (Standard)	OCR	303-0971●
4.065"	3.0MM	.118"	Stainless Steel	Chrome	CP-20 (Standard)	OCR	303-1046●

Note: For bulk open stock rings, add a B suffix.

● New Number

★ Discontinued

Bore	Axial Height	Radial Wall	Base Material	Face Coating	Ring Type (Tension)	Position	Part Number
4.070"	1.0MM	.143"	9254 Steel	HV385	RF-13PF	UCR	301-1064
4.070"	1.0MM	.136"	9254 Steel		THM-13	LCR	302-1240
4.070"	.043"	.157"	Stainless Steel	GNS	BR-12NG	UCR	301-1175
4.070"	1.2MM	.142"	Stainless Steel	GNS	BR-12NG	UCR	301-1435●
4.070"	1.2MM	.140"	9254 Steel		THM-13	LCR	302-1543●
4.070"	1.5MM	.151"	9254 Steel	HV385	RF-13PF	UCR	301-0976
4.070"	1.5MM	.140"	Stainless Steel	GNS	BR-12NG	UCR	301-1332●
4.070"	1.5MM	.154"	9254 Steel		THM-13	LCR	302-1438●
4.070"	2.0MM	.113"	Stainless Steel	Chrome	CP-20 (Low)	OCR	303-0822
4.070"	2.0MM	.113"	Stainless Steel	Chrome	CP-20 (Standard)	OCR	303-0785
4.070"	3.0MM	.151"	Stainless Steel	Chrome	CP-20 (Low)	OCR	303-0080
4.070"	3.0MM	.118"	Stainless Steel	Chrome	CP-20 (Standard)	OCR	303-1047●
4.070"	3/16"	.201"	Stainless Steel	Chrome	CP-20 (Low)	OCR	303-0162
4.070"	3/16"	.201"	Stainless Steel	Chrome	CP-20 (Standard)	OCR	303-0122★
4.075"	.031"	.173"	Ductile Iron	PM251	PB-18PF	UCR	301-0077★
4.075"	1.0MM	.143"	9254 Steel	HV385	RF-13PF	UCR	301-1128
4.075"	1.0MM	.136"	9254 Steel		THM-13	LCR	302-1217
4.075"	.043"	.157"	Stainless Steel	GNS	BR-12NG	UCR	301-1176
4.075"	.043"	.135"	9254 Steel		THM-13	LCR	302-1253
4.075"	1.2MM	.147"	9254 Steel	PM278	BR-13PF	UCR	301-0011
4.075"	1.5MM	.151"	9254 Steel	HV385	RF-13PF	UCR	301-1247
4.075"	1.5MM	.140"	Stainless Steel	GNS	BR-12NG	UCR	301-1333●
4.075"	1.5MM	.150"	9254 Steel		THM-13	LCR	302-1352
4.075"	1.5MM	.154"	9254 Steel		THM-13	LCR	302-1439●
4.075"	1/16"	.190"	9254 Steel	PM278	BR-13PF	UCR	301-1217
4.075"	1/16"	.190"	9254 Steel	HV385	BR-13PF	UCR	301-1274●
4.075"	1/16"	.170"	Grey Iron		THG-10	LCR	302-0119
4.075"	5/64"	.170"	Ductile Iron		BT-18	LCR	302-1375●
4.075"	5/64"	.178"	Grey Iron	Chrome	BT-10UF	LCR	302-1378●
4.075"	5/64"	.147"	9254 Steel	Plasma-Moly	RF-13PF	UCR	301-1272●
4.075"	3.0MM	.158"	Stainless Steel	GNS	RFK-12NG Keystone	UCR	301-1284●
4.075"	2.0MM	.113"	Stainless Steel	Chrome	CP-20 (Low)	OCR	303-0862
4.075"	2.0MM	.113"	Stainless Steel	Chrome	CP-20 (Standard)	OCR	303-0861
4.075"	3.0MM	.138"	Stainless Steel	GNS	MCL-42NGRW (Standard)	OCR	303-0950●
4.075"	3.0MM	.118"	Stainless Steel	Chrome	CP-20 (Standard)	OCR	303-1048●

● New Number

★ Discontinued

Note: For bulk open stock rings, add a B suffix.

# OPEN STOCK RINGS



Bore	Axial Height	Radial Wall	Base Material	Face Coating	Ring Type (Tension)	Position	Part Number
4.080"	1.0MM	.143"	9254 Steel	HV385	RF-13PF	UCR	301-1065
4.080"	1.0MM	.136"	9254 Steel		THM-13	LCR	302-1286
4.080"	.043"	.157"	Stainless Steel	GNS	BR-12NG	UCR	301-1177
4.080"	1.5MM	.140"	Stainless Steel	GNS	BR-12NG	UCR	301-1334●
4.080"	1.5MM	.154"	9254 Steel		THM-13	LCR	302-1440●
4.080"	2.0MM	.113"	Stainless Steel	Chrome	CP-20 (Low)	OCR	303-0823
4.080"	2.0MM	.113"	Stainless Steel	Chrome	CP-20 (Standard)	OCR	303-0786
4.080"	3.0MM	.151"	Stainless Steel	Chrome	CP-20 (Low)	OCR	303-0081
4.080"	3.0MM	.118"	Stainless Steel	Chrome	CP-20 (Standard)	OCR	303-1049●
4.080"	3/16"	.201"	Stainless Steel	Chrome	CP-20 (Low)	OCR	303-0180
4.080"	3/16"	.201"	Stainless Steel	Chrome	CP-20 (Standard)	OCR	303-0123
4.085"	1.0MM	.143"	9254 Steel	HV385	RF-13PF	UCR	301-1129
4.085"	1.0MM	.136"	9254 Steel		THM-13	LCR	302-1218
4.085"	.043"	.171"	Stainless Steel	GNS	BR-12NG	UCR	301-1153★
4.085"	.043"	.157"	Stainless Steel	GNS	BR-12NG	UCR	301-1178
4.085"	.043"	.135"	9254 Steel		THM-13	LCR	302-1254
4.085"	1.5MM	.151"	9254 Steel	HV385	RF-13PF	UCR	301-1248
4.085"	1.5MM	.150"	9254 Steel		THM-13	LCR	302-1245
4.085"	1/16"	.190"	9254 Steel	PM278	BR-13PF	UCR	301-1218
4.085"	1/16"	.170"	Grey Iron		THG-10	LCR	302-0121
4.085"	5/64"	.178"	Grey Iron	Chrome	BT-10UF	LCR	302-1379●
4.085"	3.0MM	.158"	Stainless Steel	GNS	RFK-12NG Keystone	UCR	301-1285●
4.085"	2.0MM	.113"	Stainless Steel	Chrome	CP-20 (Low)	OCR	303-0824
4.085"	2.0MM	.113"	Stainless Steel	Chrome	CP-20 (Standard)	OCR	303-0787
4.085"	3.0MM	.138"	Stainless Steel	GNS	MCL-42NGRW (Standard)	OCR	303-0973●
4.085"	3/16"	.201"	Stainless Steel	Chrome	CP-20 (Standard)	OCR	303-0640
4.090"	1.0MM	.143"	9254 Steel	HV385	RF-13PF	UCR	301-1130
4.090"	.043"	.157"	Stainless Steel	GNS	BR-12NG	UCR	301-1179
4.090"	1.5MM	.140"	Stainless Steel	GNS	BR-12NG	UCR	301-1336●
4.090"	1.5MM	.154"	9254 Steel		THM-13	LCR	302-1442●
4.090"	2.0MM	.113"	Stainless Steel	Chrome	CP-20 (Low)	OCR	303-0825
4.090"	2.0MM	.113"	Stainless Steel	Chrome	CP-20 (Standard)	OCR	303-0788
4.090"	3.0MM	.118"	Stainless Steel	Chrome	CP-20 (Standard)	OCR	303-1051●
4.090"	3/16"	.201"	Stainless Steel	Chrome	CP-20 (Standard)	OCR	303-0124

Note: For bulk open stock rings, add a B suffix.

● New Number

★ Discontinued

Bore	Axial Height	Radial Wall	Base Material	Face Coating	Ring Type (Tension)	Position	Part Number
4.095"	1.0MM	.143"	9254 Steel	HV385	RF-13PF	UCR	301-1131
4.095"	1.0MM	.136"	9254 Steel		THM-13	LCR	302-1219
4.095"	.043"	.157"	Stainless Steel	GNS	BR-12NG	UCR	301-1180
4.095"	.043"	.135"	9254 Steel		THM-13	LCR	302-1309
4.095"	1.2MM	.147"	9254 Steel	PM278	BR-13PF	UCR	301-0013★
4.095"	1.5MM	.151"	9254 Steel	HV385	RF-13PF	UCR	301-1249
4.095"	1.5MM	.150"	9254 Steel		THM-13	LCR	302-1246
4.095"	1/16"	.190"	9254 Steel	HV385	BR-13PF	UCR	301-1281●
4.095"	5/64"	.178"	Grey Iron	Chrome	BT-10UF	LCR	302-1380●
4.095"	5/64"	.170"	Ductile Iron		BT-18	LCR	302-1389●
4.095"	3.0MM	.158"	Stainless Steel	GNS	RFK-12NG Keystone	UCR	301-1286●
4.095"	2.0MM	.113"	Stainless Steel	Chrome	CP-20 (Low)	OCR	303-0826
4.095"	2.0MM	.113"	Stainless Steel	Chrome	CP-20 (Standard)	OCR	303-0789
4.095"	3.0MM	.138"	Stainless Steel	GNS	MCL-42NGRW (Standard)	OCR	303-0974●
4.100"	1.0MM	.143"	9254 Steel	HV385	RF-13PF	UCR	301-1132
4.100"	1.0MM	.136"	9254 Steel		THM-13	LCR	302-1287
4.100"	.043"	.157"	Stainless Steel	GNS	BR-12NG	UCR	301-1181
4.100"	1.5MM	.140"	Stainless Steel	GNS	BR-12NG	UCR	301-1338●
4.100"	1.5MM	.154"	9254 Steel		THM-13	LCR	302-1444●
4.100"	2.0MM	.113"	Stainless Steel	Chrome	CP-20 (Low)	OCR	303-0827
4.100"	2.0MM	.113"	Stainless Steel	Chrome	CP-20 (Standard)	OCR	303-0790
4.100"	3.0MM	.118"	Stainless Steel	Chrome	CP-20 (Standard)	OCR	303-1053●
4.105"	1.0MM	.143"	9254 Steel	HV385	RF-13PF	UCR	301-1133
4.105"	1.0MM	.136"	9254 Steel		THM-13	LCR	302-1261
4.105"	.043"	.157"	Stainless Steel	GNS	BR-12NG	UCR	301-1182
4.105"	.043"	.135"	9254 Steel		THM-13	LCR	302-1310
4.105"	2.0MM	.113"	Stainless Steel	Chrome	CP-20 (Low)	OCR	303-0828
4.105"	2.0MM	.113"	Stainless Steel	Chrome	CP-20 (Standard)	OCR	303-0791
4.110"	1.0MM	.143"	9254 Steel	HV385	RF-13PF	UCR	301-1134
4.110"	.043"	.157"	Stainless Steel	GNS	BR-12NG	UCR	301-1183
4.110"	2.0MM	.131"	Stainless Steel	Chrome	CP-20 (Low)	OCR	303-0829
4.110"	2.0MM	.131"	Stainless Steel	Chrome	CP-20 (Standard)	OCR	303-0792
4.115"	.043"	.157"	Stainless Steel	GNS	BR-12NG	UCR	301-1184
4.115"	1.0MM	.143"	9254 Steel	HV385	RF-13PF	UCR	301-1135

● New Number

★ Discontinued

Note: For bulk open stock rings, add a B suffix.

# OPEN STOCK RINGS



Bore	Axial Height	Radial Wall	Base Material	Face Coating	Ring Type (Tension)	Position	Part Number
4.120"	1.0MM	.143"	9254 Steel	HV385	RF-13PF	UCR	301-1136
4.120"	.043"	.157"	Stainless Steel	GNS	BR-12NG	UCR	301-1215
4.120"	2.0MM	.131"	Stainless Steel	Chrome	CP-20 (Low)	OCR	303-0830
4.120"	2.0MM	.131"	Stainless Steel	Chrome	CP-20 (Standard)	OCR	303-0793
4.120"	3.0MM	.151"	Stainless Steel	Chrome	CP-20 (Low)	OCR	303-0084
4.125"	1.0MM	.143"	9254 Steel	HV385	RF-13PF	UCR	301-1066
4.125"	1.0MM	.136"	9254 Steel		THM-13	LCR	302-1220
4.125"	.043"	.157"	Stainless Steel	GNS	BR-12NG	UCR	301-1186
4.125"	.043"	.135"	9254 Steel		THM-13	LCR	302-1256
4.125"	1.2MM	.147"	9254 Steel	PM278	BR-13PF	UCR	301-0016
4.125"	1.2MM	.142"	Stainless Steel	GNS	BR-12NG	UCR	301-1445●
4.125"	1.2MM	.140"	9254 Steel		THM-13	LCR	302-1553●
4.125"	1.5MM	.151"	9254 Steel	HV385	RF-13PF	UCR	301-0981
4.125"	1.5MM	.140"	Stainless Steel	GNS	BR-12NG	UCR	301-1343●
4.125"	1.5MM	.150"	9254 Steel		THM-13	LCR	302-1270
4.125"	1.5MM	.154"	9254 Steel		THM-13	LCR	302-1449●
4.125"	1/16"	.190"	9254 Steel	PM278	BR-13PF	UCR	301-1102
4.125"	1/16"	.170"	Grey Iron		THG-10	LCR	302-0127
4.125"	5/64"	.145"	9254 Steel		THM-13	LCR	302-1395●
4.125"	2.0MM	.113"	Stainless Steel	Chrome	CP-20 (Low)	OCR	303-0831
4.125"	2.0MM	.113"	Stainless Steel	Chrome	CP-20 (Standard)	OCR	303-0794
4.125"	3.0MM	.151"	Stainless Steel	Chrome	CP-20 (Low)	OCR	303-0085
4.125"	3.0MM	.153"	Stainless Steel	Chrome	CP-20 (Standard)	OCR	303-0319
4.125"	3.0MM	.138"	Stainless Steel	GNS	MCL-42NGRW (Standard)	OCR	303-0993●
4.125"	3.0MM	.118"	Stainless Steel	Chrome	CP-20 (Standard)	OCR	303-1058●
4.125"	3/16"	.201"	Stainless Steel	Chrome	CP-20 (Low)	OCR	303-0168
4.125"	3/16"	.201"	Stainless Steel	Chrome	CP-20 (Standard)	OCR	303-0128
4.125"	3/16"	.150"	Grey Iron	Chrome	MCL-40URW (Standard)	OCR	303-0975●

Note: For bulk open stock rings, add a B suffix.

● New Number

★ Discontinued

Bore	Axial Height	Radial Wall	Base Material	Face Coating	Ring Type (Tension)	Position	Part Number
4.130"	.017"	.173"	Ductile Iron	PM251	PB-18PF	UCR	301-0057★
4.130"	.017"	.173"	PC479		PB-19	UCR	301-0234
4.130"	1.0MM	.143"	9254 Steel	HV385	RF-13PF	UCR	301-1067
4.130"	1.0MM	.136"	9254 Steel		THM-13	LCR	302-1241
4.130"	.043"	.157"	Stainless Steel	GNS	BR-12NG	UCR	301-1187
4.130"	.043"	.135"	9254 Steel		THM-13	LCR	302-1251
4.130"	1.2MM	.147"	9254 Steel	PM278	BR-13PF	UCR	301-0017
4.130"	1.2MM	.142"	Stainless Steel	GNS	BR-12NG	UCR	301-1446●
4.130"	1.2MM	.169"	Intermediate Grey Iron		THM-17	LCR	302-1383●
4.130"	1.2MM	.140"	9254 Steel		THM-13	LCR	302-1554●
4.130"	1.5MM	.151"	9254 Steel	HV385	RF-13PF	UCR	301-0982
4.130"	1.5MM	.140"	Stainless Steel	GNS	BR-12NG	UCR	301-1344●
4.130"	1.5MM	.150"	9254 Steel		THM-13	LCR	302-1311
4.130"	1.5MM	.154"	9254 Steel		THM-13	LCR	302-1450●
4.130"	1/16"	.192"	PC479		BR-19	UCR	301-0211
4.130"	1/16"	.190"	9254 Steel	PM278	BR-13PF	UCR	301-1103
4.130"	1/16"	.170"	Grey Iron		THG-10	LCR	302-0128
4.130"	2.0MM	.113"	Stainless Steel	Chrome	CP-20 (Low)	OCR	303-0832
4.130"	2.0MM	.113"	Stainless Steel	Chrome	CP-20 (Standard)	OCR	303-0795
4.130"	3.0MM	.153"	Stainless Steel	Chrome	CP-20 (Ultra Low)	OCR	303-0008
4.130"	3.0MM	.151"	Stainless Steel	Chrome	CP-20 (Low)	OCR	303-0086
4.130"	3.0MM	.153"	Stainless Steel	Chrome	CP-20 (Standard)	OCR	303-0320
4.130"	3.0MM	.118"	Stainless Steel	Chrome	CP-20 (Standard)	OCR	303-1059●
4.130"	3/16"	.201"	Stainless Steel	Chrome	CP-20 (Low)	OCR	303-0657
4.130"	3/16"	.201"	Stainless Steel	Chrome	CP-20 (Standard)	OCR	303-0666

● New Number

★ Discontinued

Note: For bulk open stock rings, add a B suffix.

# OPEN STOCK RINGS



Bore	Axial Height	Radial Wall	Base Material	Face Coating	Ring Type (Tension)	Position	Part Number
4.135"	1.0MM	.143"	9254 Steel	HV385	RF-13PF	UCR	301-1068
4.135"	1.0MM	.136"	9254 Steel		THM-13	LCR	302-1221
4.135"	.043"	.157"	Stainless Steel	GNS	BR-12NG	UCR	301-1188
4.135"	.043"	.135"	9254 Steel		THM-13	LCR	302-1248
4.135"	1.2MM	.147"	9254 Steel	PM278	BR-13PF	UCR	301-0018
4.135"	1.2MM	.142"	Stainless Steel	GNS	BR-12NG	UCR	301-1447●
4.135"	1.2MM	.140"	9254 Steel		THM-13	LCR	302-1555●
4.135"	1.5MM	.151"	9254 Steel	HV385	RF-13PF	UCR	301-0983
4.135"	1.5MM	.140"	Stainless Steel	GNS	BR-12NG	UCR	301-1345●
4.135"	1.5MM	.150"	9254 Steel		THM-13	LCR	302-1271
4.135"	1.5MM	.154"	9254 Steel		THM-13	LCR	302-1451●
4.135"	1/16"	.190"	9254 Steel	Plasma-Moly	BR-13PF	UCR	301-1276●
4.135"	1/16"	.170"	Grey Iron		THG-10	LCR	302-0291
4.135"	5/64"	.145"	9254 Steel		THM-13	LCR	302-1396●
4.135"	2.0MM	.113"	Stainless Steel	Chrome	CP-20 (Low)	OCR	303-0833
4.135"	2.0MM	.113"	Stainless Steel	Chrome	CP-20 (Standard)	OCR	303-0796
4.135"	3.0MM	.151"	Stainless Steel	Chrome	CP-20 (Low)	OCR	303-0087
4.135"	3.0MM	.153"	Stainless Steel	Chrome	CP-20 (Standard)	OCR	303-0321
4.135"	3.0MM	.138"	Stainless Steel	GNS	MCL-42NGRW (Standard)	OCR	303-0994●
4.135"	3.0MM	.118"	Stainless Steel	Chrome	CP-20 (Standard)	OCR	303-1060●
4.135"	3/16"	.201"	Stainless Steel	Chrome	CP-20 (Low)	OCR	303-0169
4.135"	3/16"	.201"	Stainless Steel	Chrome	CP-20 (Standard)	OCR	303-0129
4.140"	1.0MM	.143"	9254 Steel	HV385	RF-13PF	UCR	301-1069
4.140"	1.0MM	.136"	9254 Steel		THM-13	LCR	302-1281
4.140"	.043"	.157"	Stainless Steel	GNS	BR-12NG	UCR	301-1189
4.140"	.043"	.135"	9254 Steel		THM-13	LCR	302-1265
4.140"	1.2MM	.147"	9254 Steel	PM278	BR-13PF	UCR	301-0019
4.140"	1.2MM	.142"	Stainless Steel	GNS	BR-12NG	UCR	301-1448●
4.140"	1.2MM	.140"	9254 Steel		THM-13	LCR	302-1556●
4.140"	1.5MM	.151"	9254 Steel	HV385	RF-13PF	UCR	301-0984
4.140"	1.5MM	.140"	Stainless Steel	GNS	BR-12NG	UCR	301-1346●
4.140"	1.5MM	.150"	9254 Steel		THM-13	LCR	302-1278
4.140"	1.5MM	.154"	9254 Steel		THM-13	LCR	302-1452●
4.140"	1/16"	.190"	9254 Steel	PM278	BR-13PF	UCR	301-1214
4.140"	1/16"	.170"	Grey Iron		THG-10	LCR	302-0292
4.140"	2.0MM	.113"	Stainless Steel	Chrome	CP-20 (Low)	OCR	303-0834
4.140"	2.0MM	.113"	Stainless Steel	Chrome	CP-20 (Standard)	OCR	303-0797
4.140"	3.0MM	.153"	Stainless Steel	Chrome	CP-20 (Ultra Low)	OCR	303-0011
4.140"	3.0MM	.151"	Stainless Steel	Chrome	CP-20 (Low)	OCR	303-0088
4.140"	3.0MM	.118"	Stainless Steel	Chrome	CP-20 (Standard)	OCR	303-1061●

Note: For bulk open stock rings, add a B suffix.

● New Number

★ Discontinued

Bore	Axial Height	Radial Wall	Base Material	Face Coating	Ring Type (Tension)	Position	Part Number
4.145"	1.0MM	.143"	9254 Steel	HV385	RF-13PF	UCR	301-1070
4.145"	1.0MM	.136"	9254 Steel		THM-13	LCR	302-1222
4.145"	.043"	.160"	Ductile Iron	PM251	BR-18PF	UCR	300-0012★
4.145"	.043"	.157"	Stainless Steel	GNS	BR-12NG	UCR	301-1190
4.145"	.043"	.135"	9254 Steel		THM-13	LCR	302-1288
4.145"	1.2MM	.147"	9254 Steel	PM278	BR-13PF	UCR	301-0020
4.145"	1.2MM	.142"	Stainless Steel	GNS	BR-12NG	UCR	301-1449●
4.145"	1.2MM	.140"	9254 Steel		THM-13	LCR	302-1557●
4.145"	1.5MM	.151"	9254 Steel	HV385	RF-13PF	UCR	301-0985
4.145"	1.5MM	.140"	Stainless Steel	GNS	BR-12NG	UCR	301-1347●
4.145"	1.5MM	.150"	9254 Steel		THM-13	LCR	302-1272
4.145"	1.5MM	.154"	9254 Steel		THM-13	LCR	302-1453●
4.145"	1/16"	.190"	9254 Steel	Plasma-Moly	BR-13PF	UCR	301-1277●
4.145"	2.0MM	.113"	Stainless Steel	Chrome	CP-20 (Low)	OCR	303-0835
4.145"	2.0MM	.113"	Stainless Steel	Chrome	CP-20 (Standard)	OCR	303-0798
4.145"	3.0MM	.151"	Stainless Steel	Chrome	CP-20 (Low)	OCR	303-0089
4.145"	3.0MM	.118"	Stainless Steel	Chrome	CP-20 (Standard)	OCR	303-1062●
4.145"	3/16"	.201"	Stainless Steel	Chrome	CP-20 (Low)	OCR	303-0170
4.145"	3/16"	.201"	Stainless Steel	Chrome	CP-20 (Standard)	OCR	303-0130
4.150"	1.0MM	.143"	9254 Steel	HV385	RF-13PF	UCR	301-1071
4.150"	1.0MM	.136"	9254 Steel		THM-13	LCR	302-1282
4.150"	.043"	.157"	Stainless Steel	GNS	BR-12NG	UCR	301-1191
4.150"	.043"	.135"	9254 Steel		THM-13	LCR	302-1313
4.150"	1.2MM	.147"	9254 Steel	PM278	BR-13PF	UCR	301-0021
4.150"	1.5MM	.151"	9254 Steel	HV385	RF-13PF	UCR	301-0986
4.150"	1.5MM	.140"	Stainless Steel	GNS	BR-12NG	UCR	301-1348●
4.150"	1.5MM	.150"	9254 Steel		THM-13	LCR	302-1279
4.150"	1.5MM	.154"	9254 Steel		THM-13	LCR	302-1454●
4.150"	1/16"	.190"	9254 Steel	PM278	BR-13PF	UCR	301-1104
4.150"	1/16"	.170"	Grey Iron		THG-10	LCR	302-0130
4.150"	2.0MM	.113"	Stainless Steel	Chrome	CP-20 (Low)	OCR	303-0836
4.150"	2.0MM	.113"	Stainless Steel	Chrome	CP-20 (Standard)	OCR	303-0799
4.150"	3.0MM	.153"	Stainless Steel	Chrome	CP-20 (Ultra Low)	OCR	303-0013
4.150"	3.0MM	.118"	Stainless Steel	Chrome	CP-20 (Standard)	OCR	303-1063●

● New Number

★ Discontinued

Note: For bulk open stock rings, add a B suffix.

# OPEN STOCK RINGS



Bore	Axial Height	Radial Wall	Base Material	Face Coating	Ring Type (Tension)	Position	Part Number
4.155"	1.0MM	.143"	9254 Steel	HV385	RF-13PF	UCR	301-1072
4.155"	1.0MM	.136"	9254 Steel		THM-13	LCR	302-1223
4.155"	.043"	.157"	Stainless Steel	GNS	BR-12NG	UCR	301-1192
4.155"	.043"	.135"	9254 Steel		THM-13	LCR	302-1260
4.155"	1.2MM	.142"	Stainless Steel	GNS	BR-12NG	UCR	301-1451●
4.155"	1.2MM	.140"	9254 Steel		THM-13	LCR	302-1559●
4.155"	1.5MM	.151"	9254 Steel	HV385	RF-13PF	UCR	301-0987
4.155"	1.5MM	.140"	Stainless Steel	GNS	BR-12NG	UCR	301-1349●
4.155"	1.5MM	.150"	9254 Steel		THM-13	LCR	302-1273
4.155"	1.5MM	.154"	9254 Steel		THM-13	LCR	302-1455●
4.155"	1/16"	.190"	9254 Steel	PM278	BR-13PF	UCR	301-1105
4.155"	1/16"	.170"	Grey Iron		THG-10	LCR	302-0131
4.155"	5/64"	.183"	Grey Iron	PM278	RF-10PF	UCR	301-0151
4.155"	1/8"	.201"	Stainless Steel	Chrome	CP-20 (Standard)	OCR	303-0043★
4.155"	2.0MM	.113"	Stainless Steel	Chrome	CP-20 (Low)	OCR	303-0837
4.155"	2.0MM	.113"	Stainless Steel	Chrome	CP-20 (Standard)	OCR	303-0800
4.155"	3.0MM	.153"	Stainless Steel	Chrome	CP-20 (Ultra Low)	OCR	303-0014
4.155"	3.0MM	.151"	Stainless Steel	Chrome	CP-20 (Low)	OCR	303-0090
4.155"	3.0MM	.153"	Stainless Steel	Chrome	CP-20 (Standard)	OCR	303-0325
4.155"	3.0MM	.118"	Stainless Steel	Chrome	CP-20 (Standard)	OCR	303-1064●
4.155"	3/16"	.201"	Stainless Steel	Chrome	CP-20 (Low)	OCR	303-0171
4.155"	3/16"	.201"	Stainless Steel	Chrome	CP-20 (Standard)	OCR	303-0131
4.160"	1.0MM	.143"	9254 Steel	HV385	RF-13PF	UCR	301-1073
4.160"	1.0MM	.136"	9254 Steel		THM-13	LCR	302-1242
4.160"	.043"	.157"	Stainless Steel	GNS	BR-12NG	UCR	301-1193
4.160"	.043"	.135"	9254 Steel		THM-13	LCR	302-1257
4.160"	1.2MM	.147"	9254 Steel	PM278	BR-13PF	UCR	301-0023
4.160"	1.2MM	.142"	Stainless Steel	GNS	BR-12NG	UCR	301-1452●
4.160"	1.2MM	.140"	9254 Steel		THM-13	LCR	302-1560●
4.160"	1.5MM	.151"	9254 Steel	HV385	RF-13PF	UCR	301-0988
4.160"	1.5MM	.140"	Stainless Steel	GNS	BR-12NG	UCR	301-1350●
4.160"	1.5MM	.150"	9254 Steel		THM-13	LCR	302-1280
4.160"	1.5MM	.154"	9254 Steel		THM-13	LCR	302-1456●
4.160"	1/16"	.192"	PC479		BR-19	UCR	301-0213
4.160"	1/16"	.190"	9254 Steel	PM278	BR-13PF	UCR	301-1106
4.160"	1/16"	.170"	Grey Iron		THG-10	LCR	302-0132
4.160"	2.0MM	.113"	Stainless Steel	Chrome	CP-20 (Low)	OCR	303-0838
4.160"	2.0MM	.113"	Stainless Steel	Chrome	CP-20 (Standard)	OCR	303-0801
4.160"	3.0MM	.118"	Stainless Steel	Chrome	CP-20 (Standard)	OCR	303-1065●

Note: For bulk open stock rings, add a B suffix.

● New Number

★ Discontinued

Bore	Axial Height	Radial Wall	Base Material	Face Coating	Ring Type (Tension)	Position	Part Number
4.165"	1.0MM	.143"	9254 Steel	HV385	RF-13PF	UCR	301-1074
4.165"	1.0MM	.136"	9254 Steel		THM-13	LCR	302-1224
4.165"	.043"	.157"	Stainless Steel	GNS	BR-12NG	UCR	301-1194
4.165"	1.5MM	.151"	9254 Steel	HV385	RF-13PF	UCR	301-0989
4.165"	1.5MM	.140"	Stainless Steel	GNS	BR-12NG	UCR	301-1351●
4.165"	1.5MM	.154"	9254 Steel		THM-13	LCR	302-1457●
4.165"	1/16"	.193"	Ductile Iron	PM251	BR-18PF	UCR	300-0111
4.165"	1/16"	.170"	Grey Iron		THG-10	LCR	302-0133
4.165"	2.0MM	.113"	Stainless Steel	Chrome	CP-20 (Low)	OCR	303-0839
4.165"	2.0MM	.113"	Stainless Steel	Chrome	CP-20 (Standard)	OCR	303-0802
4.165"	3.0MM	.154"	Stainless Steel	Chrome	CP-20 (Low)	OCR	303-0238
4.165"	3.0MM	.118"	Stainless Steel	Chrome	CP-20 (Standard)	OCR	303-1066●
4.165"	3/16"	.201"	Stainless Steel	Chrome	CP-20 (Low)	OCR	303-0172
4.165"	3/16"	.201"	Stainless Steel	Chrome	CP-20 (Standard)	OCR	303-0132
4.170"	1.0MM	.143"	9254 Steel	HV385	RF-13PF	UCR	301-1075
4.170"	1.0MM	.136"	9254 Steel		THM-13	LCR	302-1243
4.170"	.043"	.157"	Stainless Steel	GNS	BR-12NG	UCR	301-1195
4.170"	.043"	.135"	9254 Steel		THM-13	LCR	302-1266
4.170"	1.2MM	.147"	9254 Steel	PM278	BR-13PF	UCR	301-0025
4.170"	1.5MM	.151"	9254 Steel	HV385	RF-13PF	UCR	301-0990
4.170"	1.5MM	.150"	9254 Steel		THM-13	LCR	302-1312
4.170"	1/16"	.192"	PC479		BR-19	UCR	301-0214
4.170"	1/16"	.190"	9254 Steel	PM278	BR-13PF	UCR	301-1107
4.170"	1/16"	.170"	Grey Iron		THG-10	LCR	302-0134
4.170"	2.0MM	.113"	Stainless Steel	Chrome	CP-20 (Low)	OCR	303-0840
4.170"	2.0MM	.113"	Stainless Steel	Chrome	CP-20 (Standard)	OCR	303-0803
4.170"	3.0MM	.153"	Stainless Steel	Chrome	CP-20 (Ultra Low)	OCR	303-0017
4.170"	3.0MM	.153"	Stainless Steel	Chrome	CP-20 (Ultra Low)	OCR	303-0016
4.170"	3.0MM	.154"	Stainless Steel	Chrome	CP-20 (Low)	OCR	303-0239
4.175"	1.0MM	.143"	9254 Steel	HV385	RF-13PF	UCR	301-1076
4.175"	1.0MM	.136"	9254 Steel		THM-13	LCR	302-1225
4.175"	.043"	.157"	Stainless Steel	GNS	BR-12NG	UCR	301-1196
4.175"	.043"	.170"	Grey Iron		RBT-10	LCR	302-0018★
4.175"	.043"	.135"	9254 Steel		THM-13	LCR	302-1289
4.175"	1.5MM	.151"	9254 Steel	HV385	RF-13PF	UCR	301-0991
4.175"	1.5MM	.150"	9254 Steel		THM-13	LCR	302-1274
4.175"	2.0MM	.113"	Stainless Steel	Chrome	CP-20 (Low)	OCR	303-0841
4.175"	2.0MM	.113"	Stainless Steel	Chrome	CP-20 (Standard)	OCR	303-0804
4.175"	3.0MM	.153"	Stainless Steel	Chrome	CP-20 (Ultra Low)	OCR	303-0018

● New Number

★ Discontinued

Note: For bulk open stock rings, add a B suffix.

# OPEN STOCK RINGS



Bore	Axial Height	Radial Wall	Base Material	Face Coating	Ring Type (Tension)	Position	Part Number
4.180"	1.0MM	.143"	9254 Steel	HV385	RF-13PF	UCR	301-1078
4.180"	.043"	.171"	Stainless Steel	GNS	BR-12NG	UCR	301-1158★
4.180"	.043"	.157"	Stainless Steel	GNS	BR-12NG	UCR	301-1197
4.180"	.043"	.170"	Grey Iron		RBT-10	LCR	302-0019★
4.180"	.043"	.135"	9254 Steel		THM-13	LCR	302-1258
4.180"	1.5MM	.151"	9254 Steel	HV385	RF-13PF	UCR	301-0992
4.180"	1.5MM	.150"	9254 Steel		THM-13	LCR	302-1381●
4.180"	2.0MM	.113"	Stainless Steel	Chrome	CP-20 (Low)	OCR	303-0842
4.180"	2.0MM	.113"	Stainless Steel	Chrome	CP-20 (Standard)	OCR	303-0805
4.180"	3.0MM	.153"	Stainless Steel	Chrome	CP-20 (Ultra Low)	OCR	303-0019
4.185"	1.0MM	.143"	9254 Steel	HV385	RF-13PF	UCR	301-1080
4.185"	1.0MM	.136"	9254 Steel		THM-13	LCR	302-1226
4.185"	.043"	.157"	Stainless Steel	GNS	BR-12NG	UCR	301-1198
4.185"	.043"	.135"	9254 Steel		THM-13	LCR	302-1259
4.185"	1.5MM	.151"	9254 Steel	HV385	RF-13PF	UCR	301-0993
4.185"	1.5MM	.140"	Stainless Steel	GNS	BR-12NG	UCR	301-1355●
4.185"	1.5MM	.150"	9254 Steel		THM-13	LCR	302-1275
4.185"	1.5MM	.154"	9254 Steel		THM-13	LCR	302-1461●
4.185"	1/16"	.170"	Grey Iron		THG-10	LCR	302-0137
4.185"	2.0MM	.113"	Stainless Steel	Chrome	CP-20 (Low)	OCR	303-0843
4.185"	2.0MM	.113"	Stainless Steel	Chrome	CP-20 (Standard)	OCR	303-0806
4.185"	2.0MM	.113"	Stainless Steel	Chrome	CP-20 (Standard)	OCR	303-1011●
4.185"	3.0MM	.154"	Stainless Steel	Chrome	CP-20 (Low)	OCR	303-0240
4.185"	3.0MM	.138"	Stainless Steel	GNS	MCL-42NGAW (Standard)	OCR	303-1000●
4.185"	3.0MM	.118"	Stainless Steel	Chrome	CP-20 (Standard)	OCR	303-1070●
4.185"	3/16"	.201"	Stainless Steel	Chrome	CP-20 (Low)	OCR	303-0174
4.185"	3/16"	.201"	Stainless Steel	Chrome	CP-20 (Standard)	OCR	303-0133
4.187"	.010"	.173"	PC479		PB-19	UCR	301-0886
4.187"	.043"	.175"	9254 Steel	PVD	BR-13DV	UCR	301-1370●
4.187"	1/16"	.175"	9254 Steel	PVD	BR-13DV	UCR	301-1273
4.187"	5/64"	.170"	Ductile Iron	Plasma-Moly	PB-18PF	UCR	301-0271
4.187"	3.0MM	.154"	Stainless Steel	Chrome	CP-20 (Low)	OCR	303-0241
4.187"	3/16"	.201"	Stainless Steel	Chrome	CP-20 (High)	OCR	303-0186

Note: For bulk open stock rings, add a B suffix. ● New Number ★ Discontinued

Bore	Axial Height	Radial Wall	Base Material	Face Coating	Ring Type (Tension)	Position	Part Number
4.190"	.017"	.173"	Ductile Iron	PM251	PB-18PF	UCR	301-0060
4.190"	.017"	.173"	PC479		PB-19	UCR	301-0236
4.190"	1.0MM	.143"	9254 Steel	HV385	RF-13PF	UCR	301-1081
4.190"	1.0MM	.136"	9254 Steel		THM-13	LCR	302-1283
4.190"	.043"	.157"	Stainless Steel	GNS	BR-12NG	UCR	301-1199
4.190"	.043"	.135"	9254 Steel		THM-13	LCR	302-1296
4.190"	1.5MM	.151"	9254 Steel	HV385	RF-13PF	UCR	301-0994
4.190"	1.5MM	.140"	Stainless Steel	GNS	BR-12NG	UCR	301-1356●
4.190"	1.5MM	.154"	9254 Steel		THM-13	LCR	302-1462●
4.190"	1/16"	.192"	PC479		BR-19	UCR	301-0215
4.190"	1/16"	.170"	Grey Iron		THG-10	LCR	302-0138
4.190"	5/64"	.193"	Ductile Iron	PM251	BR-18PF	UCR	300-0199
4.190"	2.0MM	.113"	Stainless Steel	Chrome	CP-20 (Low)	OCR	303-0844
4.190"	2.0MM	.113"	Stainless Steel	Chrome	CP-20 (Standard)	OCR	303-0807
4.190"	3.0MM	.153"	Stainless Steel	Chrome	CP-20 (Ultra Low)	OCR	303-0021
4.190"	3.0MM	.118"	Stainless Steel	Chrome	CP-20 (Standard)	OCR	303-1071●
4.195"	1.0MM	.136"	9254 Steel		THM-13	LCR	302-1227
4.195"	.043"	.157"	Stainless Steel	GNS	BR-12NG	UCR	301-1200
4.195"	1.5MM	.140"	Stainless Steel	GNS	BR-12NG	UCR	301-1357●
4.195"	1.5MM	.150"	9254 Steel		THM-13	LCR	302-1276
4.195"	1.5MM	.154"	9254 Steel		THM-13	LCR	302-1463●
4.195"	2.0MM	.113"	Stainless Steel	Chrome	CP-20 (Low)	OCR	303-0845
4.195"	3.0MM	.153"	Stainless Steel	Chrome	CP-20 (Ultra Low)	OCR	303-0022
4.195"	3.0MM	.154"	Stainless Steel	Chrome	CP-20 (Low)	OCR	303-0243
4.195"	3.0MM	.118"	Stainless Steel	Chrome	CP-20 (Standard)	OCR	303-1072●
4.200"	1.0MM	.143"	9254 Steel	HV385	RF-13PF	UCR	301-1082
4.200"	.043"	.157"	Stainless Steel	GNS	BR-12NG	UCR	301-1201
4.200"	1.2MM	.147"	9254 Steel	PM278	BR-13PF	UCR	301-0031★
4.200"	1.5MM	.151"	9254 Steel	HV385	RF-13PF	UCR	301-0995
4.200"	1.5MM	.140"	Stainless Steel	GNS	BR-12NG	UCR	301-1358●
4.200"	1.5MM	.154"	9254 Steel		THM-13	LCR	302-1464●
4.200"	1/16"	.194"	Ductile Iron	PM251	BR-18PF	UCR	300-0603★
4.200"	2.0MM	.113"	Stainless Steel	Chrome	CP-20 (Low)	OCR	303-0846
4.200"	3.0MM	.153"	Stainless Steel	Chrome	CP-20 (Ultra Low)	OCR	303-0023
4.200"	3.0MM	.118"	Stainless Steel	Chrome	CP-20 (Standard)	OCR	303-1073●

● New Number

★ Discontinued

Note: For bulk open stock rings, add a B suffix.

# OPEN STOCK RINGS



Bore	Axial Height	Radial Wall	Base Material	Face Coating	Ring Type (Tension)	Position	Part Number
4.205"	1.0MM	.136"	9254 Steel		THM-13	LCR	302-1228
4.205"	.043"	.171"	Stainless Steel	GNS	BR-12NG	UCR	301-1160
4.205"	.043"	.157"	Stainless Steel	GNS	BR-12NG	UCR	301-1202
4.205"	.043"	.135"	9254 Steel		THM-13	LCR	302-1382●
4.205"	1.2MM	.147"	9254 Steel	PM278	BR-13PF	UCR	301-0032★
4.205"	1.5MM	.150"	9254 Steel		THM-13	LCR	302-1277
4.205"	3.0MM	.153"	Stainless Steel	Chrome	CP-20 (Ultra Low)	OCR	303-0024
4.213"	3.0MM	.138"	Stainless Steel	GNS	MCL-42NGAW (Standard)	OCR	303-1001●
4.215"	1/16"	.175"	9254 Steel	PVD	BR-13DV	UCR	301-1294●
4.215"	5/64"	.145"	9254 Steel		THM-13	LCR	302-1401●
4.233"	3.0MM	.138"	Stainless Steel	GNS	MCL-42NGAW (Standard)	OCR	303-1002●
4.235"	1/16"	.175"	9254 Steel	PVD	BR-13DV	UCR	301-1293●
4.235"	5/64"	.145"	9254 Steel		THM-13	LCR	302-1402●
4.235"	3.0MM	.153"	Stainless Steel	Chrome	CP-20 (Ultra Low)	OCR	303-0030
4.245"	2.0MM	.113"	Stainless Steel	Chrome	CP-20 (Standard)	OCR	303-0939
4.250"	1.0MM	.143"	9254 Steel	HV385	RF-13PF	UCR	301-1083
4.250"	1.0MM	.136"	9254 Steel		THM-13	LCR	302-1229
4.250"	.043"	.171"	Stainless Steel	GNS	BR-12NG	UCR	301-1154
4.250"	.043"	.135"	9254 Steel		THM-13	LCR	302-1341
4.250"	1/16"	.190"	9254 Steel	PM278	BR-13PF	UCR	301-1108
4.250"	1/16"	.175"	9254 Steel	PVD	BR-13DV	UCR	301-1292●
4.250"	1/16"	.170"	Grey Iron		THG-10	LCR	302-0139
4.250"	5/64"	.198"	Grey Iron	PM278	RF-10PF	UCR	300-0214
4.250"	5/64"	.145"	9254 Steel		THM-13	LCR	302-1403●
4.250"	2.0MM	.113"	Stainless Steel	Chrome	CP-20 (Low)	OCR	303-0945
4.250"	2.0MM	.113"	Stainless Steel	Chrome	CP-20 (Standard)	OCR	303-0940
4.250"	2.0MM	.113"	Stainless Steel	Chrome	CP-20 (Standard)	OCR	303-0995●
4.250"	3.0MM	.154"	Stainless Steel	Chrome	CP-20 (Low)	OCR	303-0188
4.250"	3.0MM	.138"	Stainless Steel	GNS	MCL-42NGAW (Standard)	OCR	303-1003●
4.250"	3/16"	.201"	Stainless Steel	Chrome	CP-20 (Standard)	OCR	303-0134
4.250"	3/16"	.201"	Stainless Steel	Chrome	CP-20 (High)	OCR	303-0187

Note: For bulk open stock rings, add a B suffix.

● New Number

★ Discontinued

Bore	Axial Height	Radial Wall	Base Material	Face Coating	Ring Type (Tension)	Position	Part Number
4.255"	.017"	.173"	Ductile Iron	PM251	PB-18PF	UCR	301-0062
4.255"	.017"	.173"	PC479		PB-19	UCR	301-0237
4.255"	1.0MM	.143"	9254 Steel	HV385	RF-13PF	UCR	301-1084
4.255"	1.0MM	.136"	9254 Steel		THM-13	LCR	302-1302
4.255"	.043"	.171"	Stainless Steel	GNS	BR-12NG	UCR	301-1216●
4.255"	.043"	.135"	9254 Steel		THM-13	LCR	302-1342
4.255"	1/16"	.190"	9254 Steel	PM278	BR-13PF	UCR	301-1109
4.255"	1/16"	.170"	Grey Iron		THG-10	LCR	302-0140
4.255"	2.0MM	.113"	Stainless Steel	Chrome	CP-20 (Low)	OCR	303-0946
4.255"	2.0MM	.113"	Stainless Steel	Chrome	CP-20 (Standard)	OCR	303-0941
4.260"	1.0MM	.143"	9254 Steel	HV385	RF-13PF	UCR	301-1085
4.260"	1.0MM	.136"	9254 Steel		THM-13	LCR	302-1230
4.260"	2.0MM	.113"	Stainless Steel	Chrome	CP-20 (Low)	OCR	303-0947
4.260"	2.0MM	.113"	Stainless Steel	Chrome	CP-20 (Standard)	OCR	303-0942
4.260"	3.0MM	.154"	Stainless Steel	Chrome	CP-20 (Standard)	OCR	303-0190★
4.265"	1.0MM	.143"	9254 Steel	HV385	RF-13PF	UCR	301-1086
4.265"	1.0MM	.136"	9254 Steel		THM-13	LCR	302-1303
4.265"	2.0MM	.113"	Stainless Steel	Chrome	CP-20 (Low)	OCR	303-0948
4.265"	2.0MM	.113"	Stainless Steel	Chrome	CP-20 (Standard)	OCR	303-0943
4.270"	1.0MM	.143"	9254 Steel	HV385	RF-13PF	UCR	301-1087
4.270"	1.0MM	.136"	9254 Steel		THM-13	LCR	302-1231
4.270"	2.0MM	.113"	Stainless Steel	Chrome	CP-20 (Low)	OCR	303-0949
4.270"	2.0MM	.113"	Stainless Steel	Chrome	CP-20 (Standard)	OCR	303-0944
4.270"	3/16"	.201"	Stainless Steel	Chrome	CP-20 (Low)	OCR	303-0176
4.275"	1.0MM	.143"	9254 Steel	HV385	RF-13PF	UCR	301-1088
4.275"	.043"	.135"	9254 Steel		THM-13	LCR	302-1343
4.280"	1.0MM	.143"	9254 Steel	HV385	RF-13PF	UCR	301-1089
4.280"	1.0MM	.136"	9254 Steel		THM-13	LCR	302-1232
4.280"	1/16"	.190"	9254 Steel	PM278	BR-13PF	UCR	301-1110
4.280"	1/16"	.170"	Grey Iron		THG-10	LCR	302-0141
4.280"	5/64"	.198"	Grey Iron	PM278	RF-10PF	UCR	303-0216
4.280"	3.0MM	.154"	Stainless Steel	Chrome	CP-20 (Low)	OCR	303-0194
4.280"	3/16"	.201"	Stainless Steel	Chrome	CP-20 (Low)	OCR	303-0177
4.280"	3/16"	.201"	Stainless Steel	Chrome	CP-20 (Standard)	OCR	303-0136

● New Number

★ Discontinued

Note: For bulk open stock rings, add a B suffix.

# OPEN STOCK RINGS



Bore	Axial Height	Radial Wall	Base Material	Face Coating	Ring Type (Tension)	Position	Part Number
4.285"	1.0MM	.143"	9254 Steel	HV385	RF-13PF	UCR	301-1090
4.285"	.043"	.160"	Ductile Iron	PM278	BR-18PF	UCR	300-0383
4.285"	.043"	.135"	9254 Steel		THM-13	LCR	302-1344
4.285"	1/16"	.198"	PC479		BR-19	UCR	301-0217
4.285"	1/16"	.190"	9254 Steel	PM278	BR-13PF	UCR	301-1111★
4.285"	1/16"	.170"	Grey Iron		THG-10	LCR	302-0142
4.285"	5/64"	.198"	Ductile Iron	PM251	BR-18PF	UCR	300-0217
4.290"	1.0MM	.136"	9254 Steel		THM-13	LCR	302-1233
4.290"	3/16"	.201"	Stainless Steel	Chrome	CP-20 (Standard)	OCR	303-0137
4.295"	1.0MM	.143"	9254 Steel	HV385	RF-13PF	UCR	301-1091
4.295"	.043"	.135"	9254 Steel		THM-13	LCR	302-1345
4.300"	1.0MM	.136"	9254 Steel		THM-13	LCR	302-1234
4.305"	1.0MM	.143"	9254 Steel	HV385	RF-13PF	UCR	301-1092
4.305"	.043"	.135"	9254 Steel		THM-13	LCR	302-1346
4.310"	1.0MM	.136"	9254 Steel		THM-13	LCR	302-1235
4.310"	.043"	.175"	9254 Steel	PVD	BR-13DV	UCR	301-1371●
4.310"	.043"	.175"	9254 Steel		RF-13	LCR	302-1479●
4.310"	1/16"	.190"	9254 Steel	PM278	BR-13PF	UCR	301-1112
4.310"	1/16"	.170"	Grey Iron		THG-10	LCR	302-0145
4.310"	5/64"	.198"	Grey Iron	PM278	RF-10PF	UCR	300-0218
4.310"	3.0MM	.154"	Stainless Steel	Chrome	CP-20 (Low)	OCR	303-0200
4.310"	3/16"	.201"	Stainless Steel	Chrome	CP-20 (Low)	OCR	303-0179
4.310"	3/16"	.201"	Stainless Steel	Chrome	CP-20 (Standard)	OCR	303-0138
4.310"	3/16"	.201"	Stainless Steel	Chrome	CP-20 (High)	OCR	303-0646
4.315"	.017"	.173"	PC479		PB-19	UCR	301-0239
4.315"	.031"	.173"	Ductile Iron	PM251	PB-18PF	UCR	301-0088
4.315"	1.0MM	.143"	9254 Steel	HV385	RF-13PF	UCR	301-1093
4.315"	.043"	.160"	Ductile Iron	PM251	BR-18PF	UCR	300-0384
4.315"	.043"	.198"	Ductile Iron	PM278	BR-18PF	UCR	300-0356
4.315"	.043"	.135"	9254 Steel		THM-13	LCR	302-1347
4.315"	1/16"	.198"	PC479		BR-19	UCR	301-0218
4.315"	1/16"	.190"	9254 Steel	PM278	BR-13PF	UCR	301-1113
4.315"	1/16"	.170"	Grey Iron		THG-10	LCR	302-0146
4.315"	1/16"	.198"	Ductile Iron		RBT-18	LCR	302-1157★
4.315"	5/64"	.198"	Ductile Iron	PM251	BR-18PF	UCR	300-0219

Note: For bulk open stock rings, add a B suffix.

● New Number

★ Discontinued

Bore	Axial Height	Radial Wall	Base Material	Face Coating	Ring Type (Tension)	Position	Part Number
4.320"	1.0MM	.143"	9254 Steel	HV385	RF-13PF	UCR	301-1094
4.320"	1.0MM	.136"	9254 Steel		THM-13	LCR	302-1236
4.320"	.043"	.135"	9254 Steel		THM-13	LCR	302-1348
4.320"	3.0MM	.154"	Stainless Steel	Chrome	CP-20 (Low)	OCR	303-0246
4.320"	3/16"	.201"	Stainless Steel	Chrome	CP-20 (Standard)	OCR	303-0258
4.325"	.043"	.135"	9254 Steel		THM-13	LCR	302-1349
4.325"	1/16"	.201"	Ductile Iron	PM251	BR-18PF	UCR	300-0181
4.325"	1/16"	.170"	Grey Iron		THG-10	LCR	302-1067
4.350"	.043"	.135"	9254 Steel		THM-13	LCR	302-1350
4.350"	5/64"	.201"	Grey Iron		RBT-10	LCR	302-1161
4.350"	3.0MM	.154"	Stainless Steel	Chrome	CP-20 (Low)	OCR	303-0249
4.350"	3/16"	.201"	Stainless Steel	Chrome	CP-20 (Standard)	OCR	303-0261
4.355"	.043"	.171"	Stainless Steel	GNS	BR-12NG	UCR	301-1204
4.355"	.043"	.135"	9254 Steel		THM-13	LCR	302-1351
4.355"	1/16"	.201"	PC479		BR-19	UCR	301-0220
4.355"	1/16"	.190"	9254 Steel	PM278	BR-13PF	UCR	301-1114
4.355"	1/16"	.170"	Grey Iron		THG-10	LCR	302-1069
4.355"	5/64"	.201"	Ductile Iron	PM251	BR-18PF	UCR	300-0190★
4.360"	3/16"	.201"	Stainless Steel	Chrome	CP-20 (Standard)	OCR	303-0139
4.365"	1/16"	.190"	9254 Steel	PM278	BR-13PF	UCR	301-1115
4.365"	1/16"	.170"	Grey Iron		THG-10	LCR	302-1290
4.375"	.043"	.175"	9254 Steel	PVD	BR-13DV	UCR	301-1372●
4.375"	.043"	.175"	9254 Steel		RFG-13	LCR	302-1480●
4.375"	1/16"	.190"	9254 Steel	HV385	BR-13PF	UCR	301-1275●
4.375"	1/16"	.175"	9254 Steel	PVD	BR-13DV	UCR	301-1295●
4.375"	1/16"	.170"	9254 Steel		RFG-13	LCR	302-1385●
4.375"	3.0MM	.135"	Stainless Steel	GNS / PVD	MCL-43DVAV (Standard)	OCR	303-1079●
4.375"	3/16"	.201"	Stainless Steel	Chrome	CP-20 (Low)	OCR	303-0278
4.375"	3/16"	.201"	Stainless Steel	Chrome	CP-20 (Standard)	OCR	303-0290
4.375"	3/16"	.201"	Stainless Steel	Chrome	CP-20 (High)	OCR	303-0296
4.375"	3/16"	.201"	Stainless Steel	Chrome	CP-20 (X High)	OCR	303-1088●

● New Number

★ Discontinued

Note: For bulk open stock rings, add a B suffix.

# OPEN STOCK RINGS



Bore	Axial Height	Radial Wall	Base Material	Face Coating	Ring Type (Tension)	Position	Part Number
4.380"	.017"	.173"	PC479		PB-19	UCR	301-0240
4.380"	.017"	.173"	Ductile Iron	PM251	PB-18PF	UCR	301-0712
4.380"	1/16"	.204"	Ductile Iron	PM251	BR-18PF	UCR	300-0180
4.380"	1/16"	.204"	PC479		BR-19	UCR	301-0222
4.380"	1/16"	.170"	Grey Iron		THG-10	LCR	302-1073
4.380"	5/64"	.193"	Grey Iron		RBT-10	LCR	303-0247
4.380"	3.0MM	.154"	Stainless Steel	Chrome	CP-20 (Low)	OCR	303-0252
4.380"	3/16"	.201"	Stainless Steel	Chrome	CP-20 (Low)	OCR	303-0182
4.380"	3/16"	.201"	Stainless Steel	Chrome	CP-20 (Standard)	OCR	303-0141
4.385"	1/16"	.190"	9254 Steel	PM278	BR-13PF	UCR	301-1116
4.390"	3/16"	.201"	Stainless Steel	Chrome	CP-20 (Low)	OCR	303-0183
4.390"	3/16"	.201"	Stainless Steel	Chrome	CP-20 (Standard)	OCR	303-0142
4.395"	1/16"	.190"	9254 Steel	PM278	BR-13PF	UCR	301-1117
4.395"	1/16"	.170"	Grey Iron		THG-10	LCR	302-1075
4.425"	1/16"	.170"	Grey Iron		THG-10	LCR	302-0315
4.437"	3/16"	.201"	Stainless Steel	Chrome	CP-20 (Standard)	OCR	303-0642
4.440"	.043"	.170"	9254 Steel	PVD	BR-13DV	UCR	301-1461●
4.440"	.043"	.175"	9254 Steel		RFG-13	LCR	302-1569●
4.440"	1/16"	.170"	9254 Steel	PVD	BR-13DV	UCR	301-1462●
4.440"	1/16"	.170"	9254 Steel		RFG-13	LCR	302-1570●
4.440"	3/16"	.201"	Stainless Steel	Chrome	CP-20 (X High)	OCR	303-1092●
4.445"	.043"	.171"	Stainless Steel	GNS	BR-12NG	UCR	301-1219
4.445"	1/16"	.207"	PC479		BR-19	UCR	301-0226
4.445"	1/16"	.190"	9254 Steel	PM278	BR-13PF	UCR	301-1118
4.445"	1/16"	.170"	Grey Iron		THG-10	LCR	302-0316
4.467"	3/16"	.201"	Stainless Steel	Chrome	CP-20 (Standard)	OCR	303-0643
4.467"	3/16"	.201"	Stainless Steel	Chrome	CP-20 (High)	OCR	303-0298
4.470"	.017"	.173"	PC479		PB-19	UCR	301-0242
4.470"	.043"	.175"	9254 Steel	PVD	BR-13DV	UCR	301-1373●
4.470"	.043"	.175"	9254 Steel		RFG-13	LCR	302-1481●
4.470"	1/16"	.190"	9254 Steel	HV385	BR-13PF	UCR	301-1250
4.470"	1/16"	.175"	9254 Steel	PVD	BR-13DV	UCR	301-1296●
4.470"	1/16"	.170"	Grey Iron		THG-10	LCR	302-1315
4.470"	1/16"	.170"	9254 Steel		RFG-13	LCR	302-1386●
4.470"	3.0MM	.135"	Stainless Steel	GNS / PVD	MCL-43DVAW (Standard)	OCR	303-1080●
4.470"	3/16"	.201"	Stainless Steel	Chrome	CP-20 (X High)	OCR	303-1089●

Note: For bulk open stock rings, add a B suffix.

● New Number

★ Discontinued

Bore	Axial Height	Radial Wall	Base Material	Face Coating	Ring Type (Tension)	Position	Part Number
4.475"	1/16"	.190"	9254 Steel	PM278	BR-13PF	UCR	301-1119
4.475"	1/16"	.170"	Grey Iron		THG-10	LCR	302-0317
4.500"	.043"	.210"	Ductile Iron	PM278	BR-18PF	UCR	300-0367
4.500"	1/16"	.190"	9254 Steel	HV385	RF-13PF	UCR	301-1278●
4.500"	1/16"	.175"	9254 Steel	PVD	BR-13DV	UCR	301-1297●
4.500"	1/16"	.170"	9254 Steel		RFG-13	LCR	302-1387●
4.500"	.0935"	.210"	Ductile Iron	Plasma-Moly	RF-18PF	UCR	300-0694
4.500"	3.0MM	.151"	Stainless Steel	Chrome	CP-20 (Low)	OCR	303-0092
4.500"	3.0MM	.135"	9254 Steel	PVD	MCL-42NPAW (Standard)	OCR	303-0976●
4.500"	3/16"	.201"	Stainless Steel	Chrome	CP-20 (Low)	OCR	303-0204
4.500"	3/16"	.201"	Stainless Steel	Chrome	CP-20 (Standard)	OCR	303-0359
4.500"	3/16"	.201"	Stainless Steel	Chrome	CP-20 (High)	OCR	303-0647
4.500"	3/16"	.201"	Stainless Steel	Chrome	CP-20 (X High)	OCR	303-1090●
4.505"	.017"	.173"	PC479		PB-19	UCR	301-0245
4.505"	.043"	.171"	Stainless Steel	GNS	BR-12NG	UCR	301-1097
4.505"	.043"	.175"	9254 Steel	PVD	BR-13DV	UCR	301-1374●
4.505"	.043"	.135"	9254 Steel		THM-13	LCR	302-1249
4.505"	.043"	.175"	9254 Steel		RFG-13	LCR	302-1482●
4.505"	1/16"	.210"	PC479		BR-19	UCR	301-0228
4.505"	1/16"	.190"	9254 Steel	PM278	BR-13PF	UCR	301-1120
4.505"	1/16"	.170"	Grey Iron		THG-10	LCR	302-0319
4.525"	.043"	.175"	9254 Steel	PVD	BR-13DV	UCR	301-1375●
4.525"	.043"	.175"	9254 Steel		RFG-13	LCR	302-1483●
4.530"	3.0MM	.151"	Stainless Steel	Chrome	CP-20 (Low)	OCR	303-0093★
4.530"	3.0MM	.135"	9254 Steel	PVD	MCL-42NPAW (Standard)	OCR	303-0977●
4.530"	3/16"	.201"	Stainless Steel	Chrome	CP-20 (Standard)	OCR	303-0360
4.530"	3/16"	.201"	Stainless Steel	Chrome	CP-20 (High)	OCR	303-0648
4.535"	.043"	.171"	Stainless Steel	GNS	BR-12NG	UCR	301-1098
4.535"	.043"	.175"	9254 Steel	PVD	BR-13DV	UCR	301-1376●
4.535"	.043"	.175"	9254 Steel		RFG-13	LCR	302-1484●
4.535"	1/16"	.210"	PC479		BR-19	UCR	301-0230
4.535"	1/16"	.190"	9254 Steel	PM278	BR-13PF	UCR	301-1121
4.535"	1/16"	.170"	Grey Iron		THG-10	LCR	302-0320
4.560"	1/16"	.190"	9254 Steel	PM278	BR-13PF	UCR	301-1122
4.560"	3.0MM	.151"	Stainless Steel	Chrome	CP-20 (Low)	OCR	303-0094
4.560"	3.0MM	.135"	9254 Steel	PVD	MCL-42NPAW (Standard)	OCR	303-0978●
4.560"	3/16"	.201"	Stainless Steel	Chrome	CP-20 (Low)	OCR	303-0206
4.560"	3/16"	.201"	Stainless Steel	Chrome	CP-20 (High)	OCR	303-0649

● New Number

★ Discontinued

Note: For bulk open stock rings, add a B suffix.

# OPEN STOCK RINGS



Bore	Axial Height	Radial Wall	Base Material	Face Coating	Ring Type (Tension)	Position	Part Number
4.562"	3/16"	.201"	Stainless Steel	Chrome	CP-20 (Low)	OCR	303-0663
4.562"	3/16"	.201"	Stainless Steel	Chrome	CP-20 (Standard)	OCR	303-0361
4.562"	3/16"	.201"	Stainless Steel	Chrome	CP-20 (High)	OCR	303-0747
4.565"	.043"	.171"	Stainless Steel	GNS	BR-12NG	UCR	301-1099
4.565"	.043"	.175"	9254 Steel	PVD	BR-13DV	UCR	301-1377●
4.565"	.043"	.135"	9254 Steel		THM-13	LCR	302-1250
4.565"	.043"	.175"	9254 Steel		RFG-13	LCR	302-1485●
4.565"	1.5MM	.170"	Grey Iron		THG-10	LCR	302-0164
4.565"	1/16"	.210"	PC479		BR-19	UCR	301-0231
4.565"	1/16"	.190"	9254 Steel	PM278	BR-13PF	UCR	301-1123
4.565"	1/16"	.175"	9254 Steel	PVD	BR-13DV	UCR	301-1298●
4.565"	1/16"	.170"	Grey Iron		THG-10	LCR	302-0321
4.565"	1/16"	.175"	9254 Steel		RFG-13	LCR	302-1471●
4.565"	3/16"	.201"	Stainless Steel	Chrome	CP-20 (X High)	OCR	303-1091●
4.567"	.043"	.171"	Stainless Steel	GNS	BR-12NG	UCR	301-1100
4.567"	1/16"	.190"	9254 Steel	PM278	BR-13PF	UCR	301-1124
4.567"	1/16"	.212"	Grey Iron		RBT-10	LCR	302-0902
4.585"	.043"	.171"	Stainless Steel	GNS	BR-12NG	UCR	301-1203
4.600"	1.0MM	.143"	9254 Steel	HV385	RF-13PF	UCR	301-1022
4.600"	1.0MM	.136"	9254 Steel		THM-13	LCR	302-1189
4.600"	.043"	.171"	Stainless Steel	GNS	BR-12NG	UCR	301-1040
4.600"	.043"	.135"	9254 Steel		THM-13	LCR	302-1196
4.600"	1/16"	.190"	9254 Steel	PM278	BR-13PF	UCR	301-1210
4.600"	1/16"	.170"	Grey Iron		THG-10	LCR	302-0322
4.600"	2.0MM	.113"	Stainless Steel	Chrome	CP-20 (Standard)	OCR	303-0863
4.600"	3.0MM	.151"	Stainless Steel	Chrome	CP-20 (Low)	OCR	303-0095
4.600"	3.0MM	.137"	Stainless Steel	Chrome	CP-20 (Standard)	OCR	303-0895
4.600"	3.0MM	.135"	9254 Steel	PVD	MCL-42NPAW (Standard)	OCR	303-0979●
4.600"	3.0MM	.134"	Stainless Steel	Chrome	CP-20 (High)	OCR	303-1081●
4.600"	3/16"	.170"	Stainless Steel	Chrome	CP-20 (Low)	OCR	303-0202
4.600"	3/16"	.170"	Stainless Steel	Chrome	CP-20 (Standard)	OCR	303-0362
4.600"	3/16"	.170"	Stainless Steel	Chrome	CP-20 (High)	OCR	303-0650

Note: For bulk open stock rings, add a B suffix.

● New Number

★ Discontinued

Bore	Axial Height	Radial Wall	Base Material	Face Coating	Ring Type (Tension)	Position	Part Number
4.605"	1.0MM	.143"	9254 Steel	HV385	RF-13PF	UCR	301-1023
4.605"	1.0MM	.136"	9254 Steel		THM-13	LCR	302-1190
4.605"	.043"	.175"	9254 Steel	PVD	BR-13DV	UCR	301-1378●
4.605"	.043"	.171"	Stainless Steel	GNS	BR-12NG	UCR	301-1041
4.605"	.043"	.135"	9254 Steel		THM-13	LCR	302-1197
4.605"	.043"	.175"	9254 Steel		RFG-13	LCR	302-1486●
4.605"	1.5MM	.170"	Grey Iron		THG-10	LCR	302-0165
4.605"	1/16"	.212"	Ductile Iron	PM251	BR-18PF	UCR	300-0125★
4.605"	1/16"	.212"	Ductile Iron	PM251	BR-18PF	UCR	300-0612★
4.605"	1/16"	.210"	PC479		BR-19	UCR	301-0232
4.605"	1/16"	.190"	9254 Steel	PM278	BR-13PF	UCR	301-1125
4.605"	1/16"	.170"	Grey Iron		THG-10	LCR	302-0323
4.605"	2.0MM	.113"	Stainless Steel	Chrome	CP-20 (Low)	OCR	303-0870
4.605"	2.0MM	.113"	Stainless Steel	Chrome	CP-20 (Standard)	OCR	303-0864
4.605"	3.0MM	.137"	Stainless Steel	Chrome	CP-20 (Low)	OCR	303-0896
4.605"	3.0MM	.137"	Stainless Steel	Chrome	CP-20 (Standard)	OCR	303-0897
4.605"	3.0MM	.134"	Stainless Steel	Chrome	CP-20 (High)	OCR	303-1082●
4.605"	3/16"	.170"	Stainless Steel	Chrome	CP-20 (Low)	OCR	303-0883
4.605"	3/16"	.170"	Stainless Steel	Chrome	CP-20 (Standard)	OCR	303-0884
4.605"	3/16"	.170"	Stainless Steel	Chrome	CP-20 (High)	OCR	303-0885
4.610"	1.0MM	.143"	9254 Steel	HV385	RF-13PF	UCR	301-1024
4.610"	1.0MM	.136"	9254 Steel		THM-13	LCR	302-1191
4.610"	.043"	.171"	Stainless Steel	GNS	BR-12NG	UCR	301-1042
4.610"	.043"	.135"	9254 Steel		THM-13	LCR	302-1198
4.610"	1/16"	.190"	9254 Steel	PM278	BR-13PF	UCR	301-1211
4.610"	1/16"	.170"	Grey Iron		THG-10	LCR	302-1304
4.610"	2.0MM	.113"	Stainless Steel	Chrome	CP-20 (Low)	OCR	303-0871
4.610"	2.0MM	.113"	Stainless Steel	Chrome	CP-20 (Standard)	OCR	303-0865
4.610"	3.0MM	.137"	Stainless Steel	Chrome	CP-20 (Low)	OCR	303-0898
4.610"	3.0MM	.137"	Stainless Steel	Chrome	CP-20 (Standard)	OCR	303-0899
4.610"	3.0MM	.135"	9254 Steel	PVD	MCL-42NPAW (Standard)	OCR	303-0980●
4.610"	3.0MM	.134"	Stainless Steel	Chrome	CP-20 (High)	OCR	303-1083●
4.610"	3/16"	.170"	Stainless Steel	Chrome	CP-20 (Low)	OCR	303-0886
4.610"	3/16"	.170"	Stainless Steel	Chrome	CP-20 (Standard)	OCR	303-0208
4.610"	3/16"	.170"	Stainless Steel	Chrome	CP-20 (High)	OCR	303-0887

● New Number

★ Discontinued

Note: For bulk open stock rings, add a B suffix.

# OPEN STOCK RINGS



Bore	Axial Height	Radial Wall	Base Material	Face Coating	Ring Type (Tension)	Position	Part Number
4.615"	1.0MM	.136"	9254 Steel	HV385	RF-13PF	UCR	301-1025
4.615"	1.0MM	.136"	9254 Steel		THM-13	LCR	302-1192
4.615"	.043"	.171"	Stainless Steel	GNS	BR-12NG	UCR	301-1043
4.615"	.043"	.175"	9254 Steel	PVD	BR-13DV	UCR	301-1379●
4.615"	.043"	.135"	9254 Steel		THM-13	LCR	302-1199
4.615"	.043"	.175"	9254 Steel		RFG-13	LCR	302-1487●
4.615"	1/16"	.190"	9254 Steel	PM278	BR-13PF	UCR	301-1126
4.615"	1/16"	.170"	Grey Iron		THG-10	LCR	302-1237
4.615"	2.0MM	.113"	Stainless Steel	Chrome	CP-20 (Low)	OCR	303-0872
4.615"	2.0MM	.113"	Stainless Steel	Chrome	CP-20 (Standard)	OCR	303-0866
4.615"	3.0MM	.137"	Stainless Steel	Chrome	CP-20 (Low)	OCR	303-0900
4.615"	3.0MM	.137"	Stainless Steel	Chrome	CP-20 (Standard)	OCR	303-0901
4.615"	3.0MM	.134"	Stainless Steel	Chrome	CP-20 (High)	OCR	303-1084●
4.615"	3/16"	.170"	Stainless Steel	Chrome	CP-20 (Low)	OCR	303-0888
4.615"	3/16"	.170"	Stainless Steel	Chrome	CP-20 (Standard)	OCR	303-0889
4.615"	3/16"	.170"	Stainless Steel	Chrome	CP-20 (High)	OCR	303-0890
4.620"	1.0MM	.143"	9254 Steel	HV385	RF-13PF	UCR	301-1026
4.620"	1.0MM	.136"	9254 Steel		THM-13	LCR	302-1193
4.620"	.043"	.171"	Stainless Steel	GNS	BR-12NG	UCR	301-1044
4.620"	.043"	.135"	9254 Steel		THM-13	LCR	302-1200
4.620"	1/16"	.190"	9254 Steel	PM278	BR-13PF	UCR	301-1212
4.620"	1/16"	.170"	Grey Iron		THG-10	LCR	302-1305
4.620"	2.0MM	.113"	Stainless Steel	Chrome	CP-20 (Low)	OCR	303-0873
4.620"	2.0MM	.113"	Stainless Steel	Chrome	CP-20 (Standard)	OCR	303-0867
4.620"	3.0MM	.137"	Stainless Steel	Chrome	CP-20 (Low)	OCR	303-0902
4.620"	3.0MM	.137"	Stainless Steel	Chrome	CP-20 (Standard)	OCR	303-0903
4.620"	3.0MM	.134"	Stainless Steel	Chrome	CP-20 (High)	OCR	303-1085●
4.620"	3/16"	.170"	Stainless Steel	Chrome	CP-20 (Low)	OCR	303-0203
4.620"	3/16"	.170"	Stainless Steel	Chrome	CP-20 (Standard)	OCR	303-0891
4.620"	3/16"	.170"	Stainless Steel	Chrome	CP-20 (High)	OCR	303-0892

Note: For bulk open stock rings, add a B suffix.

● New Number

★ Discontinued

Bore	Axial Height	Radial Wall	Base Material	Face Coating	Ring Type (Tension)	Position	Part Number
4.625"	1.0MM	.136"	9254 Steel	HV385	RF-13PF	UCR	301-1027
4.625"	1.0MM	.136"	9254 Steel		THM-13	LCR	302-1194
4.625"	.043"	.171"	Stainless Steel	GNS	BR-12NG	UCR	301-1045
4.625"	.043"	.175"	9254 Steel	PVD	BR-13DV	UCR	301-1380●
4.625"	.043"	.135"	9254 Steel		THM-13	LCR	302-1201
4.625"	.043"	.175"	9254 Steel		RFG-13	LCR	302-1478●
4.625"	.043"	.175"	9254 Steel		RFG-13	LCR	302-1488●
4.625"	1/16"	.190"	9254 Steel	PM278	BR-13PF	UCR	301-1213
4.625"	1/16"	.170"	Grey Iron		THG-10	LCR	302-1306
4.625"	.0935"	.182"	Ductile Iron	Chrome	RF-18U	UCR	300-0661
4.625"	2.0MM	.113"	Stainless Steel	Chrome	CP-20 (Low)	OCR	303-0874
4.625"	2.0MM	.113"	Stainless Steel	Chrome	CP-20 (Standard)	OCR	303-0868
4.625"	3.0MM	.137"	Stainless Steel	Chrome	CP-20 (Low)	OCR	303-0904
4.625"	3.0MM	.137"	Stainless Steel	Chrome	CP-20 (Standard)	OCR	303-0905
4.625"	3.0MM	.135"	9254 Steel	PVD	MCL-42NPAW (Standard)	OCR	303-0981●
4.625"	3.0MM	.134"	Stainless Steel	Chrome	CP-20 (High)	OCR	303-1086●
4.625"	3/16"	.170"	Stainless Steel	Chrome	CP-20 (Low)	OCR	303-0665
4.625"	3/16"	.170"	Stainless Steel	Chrome	CP-20 (Standard)	OCR	303-0644
4.625"	3/16"	.170"	Stainless Steel	Chrome	CP-20 (High)	OCR	303-0651
4.630"	1.0MM	.143"	9254 Steel	HV385	RF-13PF	UCR	301-1028
4.630"	1.0MM	.136"	9254 Steel		THM-13	LCR	302-1195
4.630"	.043"	.171"	Stainless Steel	GNS	BR-12NG	UCR	301-1046
4.630"	.043"	.135"	9254 Steel		THM-13	LCR	302-1202
4.630"	1/16"	.190"	9254 Steel	PM278	BR-13PF	UCR	301-1127
4.630"	1/16"	.170"	Grey Iron		THG-10	LCR	302-0324
4.630"	2.0MM	.113"	Stainless Steel	Chrome	CP-20 (Low)	OCR	303-0875
4.630"	2.0MM	.113"	Stainless Steel	Chrome	CP-20 (Standard)	OCR	303-0869
4.630"	3.0MM	.137"	Stainless Steel	Chrome	CP-20 (Low)	OCR	303-0906
4.630"	3.0MM	.137"	Stainless Steel	Chrome	CP-20 (Standard)	OCR	303-0907
4.630"	3.0MM	.134"	Stainless Steel	Chrome	CP-20 (High)	OCR	303-1087●
4.630"	3/16"	.170"	Stainless Steel	Chrome	CP-20 (Low)	OCR	303-0893
4.630"	3/16"	.170"	Stainless Steel	Chrome	CP-20 (Standard)	OCR	303-0894
4.630"	3/16"	.170"	Stainless Steel	Chrome	CP-20 (High)	OCR	303-0749

● New Number

★ Discontinued

Note: For bulk open stock rings, add a B suffix.

# OPEN STOCK RINGS



Bore	Axial Height	Radial Wall	Base Material	Face Coating	Ring Type (Tension)	Position	Part Number
4.650"	1.5MM	.170"	Grey Iron		THG-10	LCR	302-0167
4.650"	3.0MM	.151"	Stainless Steel	Chrome	CP-20 (Low)	OCR	303-0097
4.680"	.043"	.175"	PC479		BR-19	UCR	301-0187
4.680"	.043"	.210"	Grey Iron		RBT-10	LCR	302-0155
4.680"	.043"	.210"	PC479		RBT-18	LCR	302-0451
4.680"	1/16"	.170"	Grey Iron		THG-10	LCR	302-0811
4.700"	2.0MM	.128"	Stainless Steel	GNS	CP-20 (Ultra Low)	OCR	303-0847
4.705"	.043"	.210"	Grey Iron		RBT-10	LCR	302-0157
4.705"	.043"	.170"	PC479		THM-18	LCR	302-1133
4.710"	2.0MM	.128"	Stainless Steel	GNS	CP-20 (Ultra Low)	OCR	303-0848
4.720"	2.0MM	.128"	Stainless Steel	GNS	CP-20 (Ultra Low)	OCR	303-0849
4.730"	2.0MM	.128"	Stainless Steel	GNS	CP-20 (Ultra Low)	OCR	303-0850
4.735"	.043"	.218"	Ductile Iron	Plasma-Moly	RBT-18PF	LCR	302-0442★
4.735"	2.0MM	.128"	Stainless Steel	GNS	CP-20 (Ultra Low)	OCR	303-0851
4.740"	2.0MM	.128"	Stainless Steel	GNS	CP-20 (Ultra Low)	OCR	303-0852
4.745"	2.0MM	.128"	Stainless Steel	GNS	CP-20 (Ultra Low)	OCR	303-0853
4.750"	2.0MM	.128"	Stainless Steel	GNS	CP-20 (Ultra Low)	OCR	303-0854
4.750"	3.0MM	.151"	Stainless Steel	Chrome	CP-20 (Low)	OCR	303-0102

Note: For bulk open stock rings, add a B suffix.

● New Number

★ Discontinued

Bore	Axial Height	Radial Wall	Base Material	Face Coating	Ring Type (Tension)	Position	Part Number
4.755"	1.5MM	.170"	Grey Iron		THG-10	LCR	302-0172★
4.755"	1.5MM	.170"	PC479		THM-18	LCR	302-1128
4.755"	2.0MM	.128"	Stainless Steel	GNS	CP-20 (Ultra Low)	OCR	303-0855
4.760"	2.0MM	.128"	Stainless Steel	GNS	CP-20 (Ultra Low)	OCR	303-0856
4.780"	3.0MM	.151"	Stainless Steel	Chrome	CP-20 (Low)	OCR	303-0103★
4.785"	1.5MM	.170"	Grey Iron		THG-10	LCR	302-0173
4.805"	1.5MM	.170"	PC479		THM-18	LCR	302-1130
4.875"	.0935"	.227"	Ductile Iron	Plasma-Moly	RF-18PF	UCR	300-0650
4.875"	.0935"	.192"	Grey Iron		BT-10	LCR	302-1165●
4.875"	3/16"	.208"	Grey Iron	Chrome	MCL-40URW (Standard)	OCR	303-0726
4.876"	.0935"	.192"	Ductile Iron	Plasma-Moly	BR-18PF	UCR	300-0678
4.905"	.043"	.190"	PC479		THM-18	LCR	302-1139
5.000"	4.0MM	.169"	Stainless Steel	GNS	MCL-42NGRW (Standard)	OCR	303-0984●
5.005"	.043"	.190"	PC479		THM-18	LCR	302-1140

● New Number

★ Discontinued

Note: For bulk open stock rings, add a B suffix.

# HASTINGS INTERCHANGES



Hastings	MAHLE Performance	Hastings	MAHLE Performance	Hastings	MAHLE Performance
2M5501.005	315-0021.005	2M5513.065	315-0022.065	2M5523.045	315-0036.045
2M5501.035	315-0021.035	2M5515.035	315-0002.035	2M5523.060	315-0036.060
2M5504	315-0051	2M5515.065	315-0002.065	2M5523.065	315-0036.065
2M5504.020	315-0051.020	2M5518	315-0028	2M5524.005	315-0004.005
2M5504.030	315-0051.030	2M5518.005	315-0028.005	2M5525.060	315-0043.065
2M5505.005	315-0005.005	2M5518.030	315-0028.030	2M5525.065	315-0043.065
2M5505.010	315-0005.010	2M5518.035	315-0028.035	2M5528	315-0029
2M5505.025	315-0005.025	2M5518.060	315-0028.060	2M5528.005	315-0029.005
2M5505.030	315-0005.035	2M5518.065	315-0028.065	2M5528.030	315-0029.030
2M5505.035	315-0005.035	2M5519	315-0035	2M5528.035	315-0029.035
2M5505.045	315-0005.045	2M5519.005	315-0014.005	2M5528.065	315-0029.065
2M5505.060	315-0005.065	2M5519.005	315-0035.005	2M5529	315-0032
2M5505.065	315-0005.065	2M5519.030	315-0035.030	2M5529.005	315-0032.005
2M5508	315-0030	2M5519.035	315-0035.035	2M5529.025	315-0032.025
2M5508	315-0034	2M5519.040	315-0035.040	2M5529.030	315-0032.030
2M5508.005	315-0030.005	2M5519.060	315-0035.060	2M5529.035	315-0032.035
2M5508.005	315-0034.005	2M5519.065	315-0035.065	2M5529.040	315-0032.040
2M5508.020	315-0034.020	2M5520.035	315-0003.035	2M5529.045	315-0032.045
2M5508.025	315-0034.025	2M5521	315-0031	2M5529.060	315-0032.060
2M5508.030	315-0034.030	2M5521	315-0033	2M5529.065	315-0032.065
2M5508.035	315-0030.035	2M5521.005	315-0031.005	2M5535	315-0020
2M5508.035	315-0034.035	2M5521.005	315-0033.005	2M5535.030	315-0020.030
2M5508.040	315-0034.040	2M5521.020	315-0031.020	2M5535.035	315-0020.040
2M5508.045	315-0034.045	2M5521.025	315-0033.025	2M5535.060	315-0020.060
2M5508.060	315-0034.060	2M5521.030	315-0031.030	2M5536.035	315-0010.035
2M5508.065	315-0030.065	2M5521.030	315-0033.030	2M5536.065	315-0010.065
2M5508.065	315-0034.065	2M5521.035	315-0031.035	2M5537	315-0053.005
2M5510.005	315-0004.005	2M5521.035	315-0033.035	2M5537.004	315-0053.005
2M5510.025	315-0004.025	2M5521.045	315-0031.045	2M5537.034	315-0053.035
2M5510.035	315-0004.035	2M5521.045	315-0033.045	2M5537.064	315-0053.065
2M5510.045	315-0004.045	2M5521.060	315-0031.060	2M5538	315-0049
2M5511.035	315-0048.035	2M5521.060	315-0033.060	2M5538.005	315-0049.005
2M5511.065	315-0048.065	2M5521.065	315-0031.065	2M5543.005	315-0047.005
2M5511005	315-0048.005	2M5521.065	315-0033.065	2M5543.035	315-0047.035
2M5513	315-0023	2M5523	315-0036	2M5543.065	315-0047.065
2M5513.005	315-0022.005	2M5523.005	315-0036.005	2M5544.005	315-0062.005
2M5513.030	315-0023.030	2M5523.025	315-0036.025	2M5544.035	315-0062.035
2M5513.035	315-0022.035	2M5523.030	315-0036.030	2M5545.005	315-0009.005
2M5513.040	315-0023.040	2M5523.035	315-0036.035	2M5545.035	315-0009.035
2M5513.060	315-0023.060	2M5523.040	315-0036.040	2M5561	315-0052

<b>Hastings</b>	<b>MAHLE Performance</b>	<b>Hastings</b>	<b>MAHLE Performance</b>
2M5561.030	315-0052.030	CM5534.040	310-0003.040
2M5561.060	315-0052.060	CR3002	315-0031
C5530	310-0009	SM8527	315-0027.005
C5530.030	310-0009.030		
C5530.040	310-0009.040		
C5530.060	310-0009.060		
C5531	310-0005		
C5531.030	310-0005.030		
C5531.040	310-0005.040		
C5531.060	310-0005.060		
C5532	310-0002		
C5532.030	310-0002.030		
C5532.040	310-0002.040		
C5532.060	310-0002.060		
C5533	310-0007		
C5533.030	310-0007.030		
C5533.040	310-0007.040		
C5533.060	310-0007.060		
C5534	310-0001		
C5534.030	310-0001.030		
C5534.040	310-0001.040		
C5534.060	310-0001.060		
CM5530	310-0010		
CM5530.030	310-0010.030		
CM5530.040	310-0010.040		
CM5530.060	310-0010.060		
CM5531	310-0006		
CM5531.030	310-0006.030		
CM5531.040	310-0006.040		
CM5531.060	310-0006.060		
CM5532	310-0004		
CM5532.030	310-0004.030		
CM5532.040	310-0004.040		
CM5532.060	310-0004.060		
CM5533	310-0008		
CM5533.030	310-0008.030		
CM5533.040	310-0008.040		
CM5533.060	310-0008.060		
CM5534	310-0003		
CM5534.030	310-0003.030		

---

# SEALED POWER INTERCHANGES



<b>Sealed Power</b>	<b>MAHLE Performance</b>	<b>Sealed Power</b>	<b>MAHLE Performance</b>	<b>Sealed Power</b>	<b>MAHLE Performance</b>
19100 35	315-0072.035	R-20101 65	315-0059.065	R-587965	315-0022.065
R-1013335	315-0057.035	R-20102	315-0060	R-588335	315-0040.035
R-101335	315-0057.005	R-20102	315-0060.020	R-595935	315-0031.035
R-1013365	315-0057.065	R-20102	315-0060.030	R-6375	310-0001
R-1013635	315-0026.035	R-20102	315-0060.040	R-637530	310-0001.030
R-1020235	315-0021.035	R-20102	315-0060.060	R-637540	310-0001.040
R-102025	315-0021.005	R-20102	315-0066	R-6902	310-0002
R-1023035	315-0009.035	R-20102.005	315-0066.005	R-6902.030	310-0002.030
R-102305	315-0009.005	R-20102.020	315-0066.020	R-6902.040	310-0002.040
R-1024635	315-0024.035	R-20102.025	315-0066.025	R-6902.060	310-0002.060
R-1024645	315-0024.045	R-20102.030	315-0066.030	R-8375	310-0003
R-102465	315-0024.005	R-20102.035	315-0066.035	R-837530	310-0003.030
R-1024935	315-0046.035	R-20102.040	315-0066.040	R-837540	310-0003.040
R-1031635	315-0054.035	R-20102.045	315-0066.045	R-8902	310-0004
R-103165	315-0054.005	R-20102.060	315-0066.060	R-890230	310-0004.030
R-1031735	315-0001.035	R-20104.005	315-0068.005	R-890240	310-0004.040
R-103175	315-0001.005	R-20104.025	315-0068.025	R-890260	310-0004.060
R-10332	315-0052	R-20105.025	315-0069.025	R-922435	315-0019.035
R-10374	315-0023	R-20106.005	315-0070.005	R-92245	315-0019.005
R-1037430	315-0023.030	R-20106.010	315-0070.010	R-922465	315-0019.065
R-1037460	315-0023.060	R-20106.025	315-0070.025	R-922835	315-0044.035
R-1045135	315-0053.035	R-20106.030	315-0070.030	R-927835	315-0003.035
R-104515	315-0053.005	R-2010735	315-0050.035	R-92785	315-0003.005
R-10471	315-0020	R-2010745	315-0050.045	R-927865	315-0003.065
R-1047130	315-0020.030	R-2010765	315-0050.065	R-928165	315-0043.065
R-1047140	315-0020.040	R-20108	315-0071	R-93325	315-0058.005
R-105195	315-0056.005	R-20108.005	315-0071.005	R-934435	315-0002.035
R-1057635	315-0013.035	R-20108.020	315-0071.020	R-93445	315-0002.005
R-105765	315-0013.005	R-20108.025	315-0071.025	R-934465	315-0002.065
R-10596	315-0039.005	R-20108.030	315-0071.030	R-934625	315-0004.025
R-10598	315-0037.005	R-20108.035	315-0071.035	R-934635	315-0004.035
R-2010025	315-0015.025	R-20108.040	315-0071.040	R-93465	315-0004.005
R-2010035	315-0015.035	R-20108.045	315-0071.045	R-93465	315-0004.015
R-201005	315-0015.005	R-20108.060	315-0071.060	R-934665	315-0004.065
R-20101 25	315-0059.025	R-20108.065	315-0071.065	R-9357	315-0008.005
R-20101 35	315-0059.035	R-5877	310-0005	R-935735	315-0008.035
R-20101 40	315-0059.040	R-587735	315-0030.035	R-935765	315-0008.065
R-20101 45	315-0059.045	R-587835	315-0048.035	R-937435	315-0010.035
R-20101 5	315-0059.005	R-587935	315-0022.035	R-93745	315-0010.005
R-20101 60	315-0059.060	R-58795	315-0022.005	R-9401	315-0005.005

<b>Sealed Power</b>	<b>MAHLE Performance</b>	<b>Sealed Power</b>	<b>MAHLE Performance</b>	<b>Sealed Power</b>	<b>MAHLE Performance</b>
R-9401	315-0005.010	R1059330	315-0025.030	R9902	315-0036
R-9401	315-0005.025	R19100 5	315-0072.005	R990230	315-0036.030
R-9401	315-0005.035	R19100 65	315-0072.065	R990260	315-0036.060
R-9401	315-0005.045	R19108 5	315-0080.005	R9903	315-0034
R-9401	315-0005.065	R19110 5	315-0082.005	R990330	315-0034.030
R-94065	315-0014.005	R20107	315-0050	R9904	315-0035
R-954835	315-0047.035	R2010935	315-0017.035	R9905	315-0028
R-95485	315-0047.005	R2010945	315-0017.045	R990530	315-0028.030
R-954865	315-0047.065	R201095	315-0017.005	R990560	315-0028.060
R-960235	315-0062.035	R2010965	315-0017.065	R9968	315-0033
R-962135	315-0012.035	R5877	315-0030	R996830	315-0033.030
R-962165	315-0012.065	R5877	315-0034	R996860	315-0033.060
R-9745	315-0035.005	R5959	315-0031		
R-974535	315-0035.035	R5959	315-0033		
R-974565	315-0035.065	R9278	315-0029		
R-979835	315-0029.030	R9342	315-0031		
R-97995	315-0018.005	R9342	315-0033		
R-990360	315-0034.060	R9342	315-0034		
R-990430	315-0035.030	R934225	315-0033.025		
R-990460	315-0035.060	R934235	315-0033.035		
R-994135	315-0016.035	R93425	315-0033.005		
R-994165	315-0016.065	R9343	315-0034		
R-998515	315-0011.015	R934325	315-0034.025		
R-998525	315-0011.025	R934335	315-0034.035		
R-99855	315-0011.005	R93435	315-0034.005		
R10136	315-0026	R9344	315-0035		
R10144	315-0036	R9401	315-0036		
R1024825	315-0032.025	R9453	315-0036		
R1024835	315-0032.035	R9590	315-0028		
R102485	315-0032.005	R959035	315-0028.035		
R10316	315-0054.005	R95905	315-0028.005		
R10375	315-0032	R959065	315-0028.065		
R1037530	315-0032.030	R9745	315-0035		
R1037540	315-0032.040	R9771	315-0036		
R1039335	315-0027.035	R977135	315-0036.035		
R1039365	315-0027.065	R977165	315-0036.065		
R10451	315-0053.005	R9798	315-0029		
R10452	315-0055.005	R979835	315-0029.035		
R10519	315-0056.005	R97985	315-0029.005		
R10593	315-0025	R979865	315-0029.065		

# MEASUREMENT EQUIVALENTS



Fraction	Decimal	MM
1/64	.01563	.3969
1/32	.03125	.7938
	.03937	1.0000
3/64	.04688	1.1906
1/16	.06250	1.5875
5/64	.07813	1.9844
	.07874	2.0000
3/32	.09375	2.3813
7/64	.10938	2.7781
	.11811	3.0000
1/8	.12500	3.1750
9/64	.14063	3.5719
5/32	.15625	3.9688
	.15748	4.0000
11/64	.17188	4.3656
3/16	.18750	4.7625
	.19685	5.0000
13/64	.20313	5.1594
7/32	.21875	5.5563
15/64	.23438	5.9531
	.23622	6.0000
1/4	.2500	6.3500
17/64	.26563	6.7469
	.27559	7.0000
9/32	.28125	7.1438
19/64	.29688	7.5406
5/16	.31250	7.9375
	.31496	8.0000
21/64	.32813	8.3344
11/32	.34375	8.7313
	.35433	9.0000
23/64	.35938	9.1281
3/8	.37500	9.5250
25/64	.39063	9.9219
	.39370	10.0000
13/32	.40625	10.3188
27/64	.42188	10.7156
	.43307	11.0000
7/16	.43750	11.1125
29/64	.45313	11.5094
15/32	.46875	11.9063
	.47244	12.0000
31/64	.48438	12.3031

Fraction	Decimal	MM
1/2	.50000	12.7000
	.51181	13.0000
33/64	.51563	13.0969
17/32	.53125	13.4938
35/64	.54688	13.8906
	.55118	14.0000
9/16	.56250	14.2875
37/64	.57813	14.6844
	.59055	15.0000
19/32	.59375	15.0813
39/64	.60938	15.4781
5/8	.62500	15.8750
	.62992	16.0000
41/64	.64063	16.2719
21/32	.65625	16.6688
	.66929	17.0000
43/64	.67188	17.0656
11/16	.68750	17.4625
45/64	.70313	17.8594
	.70866	18.0000
23/32	.71875	18.2563
47/64	.73438	18.6531
	.74803	19.0000
3/4	.75000	19.0500
49/64	.76563	19.4469
25/32	.78125	19.8438
	.78740	20.0000
51/64	.79688	20.2406
13/16	.81250	20.6375
	.82677	21.0000
53/64	.82813	21.0344
27/32	.84375	21.4313
55/64	.85938	21.8281
	.86614	22.0000
7/8	.87500	22.2250
57/64	.89063	22.6219
	.90551	23.0000
29/32	.90625	23.0188
59/64	.92188	23.4156
15/16	.93750	23.8125
	.94488	24.0000
61/64	.95313	24.2094
31/32	.96875	24.6063
	.98425	25.0000
63/64	.98438	25.0031
1	1.00000	25.4000

MM X .03937 = Inches / Inches X 25.4 = MM

## По вопросам продаж и поддержки обращайтесь:

Алматы (727)345-47-04  
Ангарск (3955)60-70-56  
Архангельск (8182)63-90-72  
Астрахань (8512)99-46-04  
Барнаул (3852)73-04-60  
Белгород (4722)40-23-64  
Благовещенск (4162)22-76-07  
Брянск (4832)59-03-52  
Владивосток (423)249-28-31  
Владикавказ (8672)28-90-48  
Владимир (4922)49-43-18  
Волгоград (844)278-03-48  
Вологда (8172)26-41-59  
Воронеж (473)204-51-73  
Екатеринбург (343)384-55-89

Иваново (4932)77-34-06  
Ижевск (3412)26-03-58  
Иркутск (395)279-98-46  
Казань (843)206-01-48  
Калининград (4012)72-03-81  
Калуга (4842)92-23-67  
Кемерово (3842)65-04-62  
Киров (8332)68-02-04  
Коломна (4966)23-41-49  
Кострома (4942)77-07-48  
Краснодар (861)203-40-90  
Красноярск (391)204-63-61  
Курск (4712)77-13-04  
Курган (3522)50-90-47  
Липецк (4742)52-20-81

Магнитогорск (3519)55-03-13  
Москва (495)268-04-70  
Мурманск (8152)59-64-93  
Набережные Челны (8552)20-53-41  
Новокузнецк (3843)20-46-81  
Ноябрьск (3496)41-32-12  
Новосибирск (383)227-86-73  
Омск (3812)21-46-40  
Орел (4862)44-53-42  
Оренбург (3532)37-68-04  
Пенза (8412)22-31-16  
Петрозаводск (8142)55-98-37  
Псков (8112)59-10-37  
Пермь (342)205-81-47

Ростов-на-Дону (863)308-18-15  
Рязань (4912)46-61-64  
Самара (846)206-03-16  
Санкт-Петербург (812)309-46-40  
Саратов (845)249-38-78  
Севастополь (8692)22-31-93  
Саранск (8342)22-96-24  
Симферополь (3652)67-13-56  
Смоленск (4812)29-41-54  
Сочи (862)225-72-31  
Ставрополь (8652)20-65-13  
Сургут (3462)77-98-35  
Сыктывкар (8212)25-95-17  
Тамбов (4752)50-40-97  
Тверь (4822)63-31-35

Тольятти (8482)63-91-07  
Томск (3822)98-41-53  
Тула (4872)33-79-87  
Тюмень (3452)66-21-18  
Ульяновск (8422)24-23-59  
Улан-Удэ (3012)59-97-51  
Уфа (347)229-48-12  
Хабаровск (4212)92-98-04  
Чебоксары (8352)28-53-07  
Челябинск (351)202-03-61  
Череповец (8202)49-02-64  
Чита (3022)38-34-83  
Якутск (4112)23-90-97  
Ярославль (4852)69-52-93

**Россия** +7(495)268-04-70

**Казахстан** +(727)345-47-04

**Беларусь** +(375)257-127-884

**Узбекистан** +998(71)205-18-59

**Киргизия** +996(312)96-26-47

эл.почта: [men@nt-rt.ru](mailto:men@nt-rt.ru) || сайт: <https://mahle.nt-rt.ru/>